

ICC-ES Evaluation Report

ESR-2854

Reissued April 2026

This report also contains:

- [City of LA Supplement](#)

Subject to renewal April 2028

- [FL Supplement w/ HVHZ](#)

ICC-ES Evaluation Reports are not to be construed as representing aesthetics or any other attributes not specifically addressed, nor are they to be construed as an endorsement of the subject of the report or a recommendation for its use. There is no warranty by ICC Evaluation Service, LLC, express or implied, as to any finding or other matter in this report, or as to any product covered by the report.

Copyright © 2026 ICC Evaluation Service, LLC. All rights reserved.

<p>DIVISION: 03 00 00— CONCRETE</p> <p>Section: 03 15 19— Cast-In Concrete Anchors</p> <p>Section: 03 16 00— Concrete Anchors</p>	<p>REPORT HOLDER: JORDAHL</p>	<p>EVALUATION SUBJECT: JORDAHL ANCHOR CHANNEL SYSTEMS IN CRACKED AND UNCRACKED CONCRETE</p>	
--	--	--	---

1.0 EVALUATION SCOPE

Compliance with the following codes:

- 2021, 2018, 2015, 2012, 2009 and 2006 [International Building Code® \(IBC\)](#)
- 2021, 2018, 2015, 2012, 2009 and 2006 [International Residential Code® \(IRC\)](#)
- 2013 *Abu Dhabi International Building Code (ADIBC)*[†]

[†]The ADIBC is based on the 2009 IBC. 2009 IBC code sections referenced in this report are the same sections in the ADIBC.

Property evaluated:

- Structural

2.0 USES

Jordahl JTA anchor channels (JTA K28/15, JTA K38/17, JTA W40/22, JTA W40+, JTA W50/30, JTA W50+, JTA W53/34, JTA W55/42, JTA W72/48) and Jordahl anchor channel bolts (JD, JH, JC, JB, and JA series), which are components of the Jordahl JTA anchor channel system, are used for anchorage in concrete to resist static, wind, and seismic (IBC Seismic Design Categories A and B) tension loads (N_{ua}), and shear loads perpendicular to the longitudinal channel axis ($V_{ua,y}$), or any combination of these loads applied at any location between the outermost anchors of the anchor channel in accordance with [Figure 2-1](#) of this report.

Jordahl JZA and JXA (-PC) serrated (toothed) anchor channels (JZA K41/22, JXA W29/20, JXA W38/23, JXA W53/34, JXA W64/44, and JXA-PC W53/34) and Jordahl serrated (toothed) anchor channel bolts (JZS, JXD, JXH, JXB, and JXE series), which are components of the Jordahl JZA, JXA and JXA-PC anchor channel system, as well as Jordahl JTA anchor channels (JTA W 40/22, JTA W 40+, JTA W 50/30, JTA W 50+, JTA W 53/34) and Jordahl notching anchor channel bolts (JKB and JKC series – steel-steel contact required), which are components of the Jordahl JTA anchor channel system, are used for anchorage in concrete to resist static, wind, and seismic (IBC Seismic Design Categories A through F) tension loads (N_{ua}), shear loads perpendicular to the longitudinal channel axis ($V_{ua,y}$), and shear loads longitudinal with the channel axis ($V_{ua,x}$), or any combination of these loads applied at any location between the outermost anchors of the anchor channel in accordance with [Figure 2-1](#) of this report

Transfer of tension loads take place via interlock between the channel bolt and the channel lips, bending of the channel, tension in the anchors, and mechanical interlock between the anchors and the concrete. Shear loads perpendicular to the longitudinal channel axis are transferred by the anchors and by compression between the side of the channel and the concrete. However, for reasons of simplicity, it is assumed that the shear loads are transferred by the anchors only. Shear loads longitudinal with the channel axis are transferred by mechanical interlock either between the serrated channel bolts and the matching serrated anchor channel, or by notches in the smooth channel profile created by notching channel bolts, and the interaction between the anchors and the concrete.

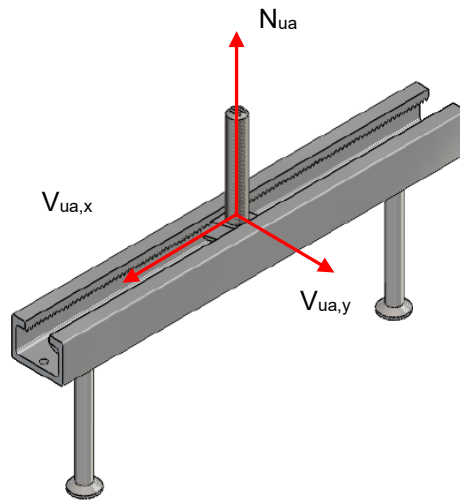

- Tension load N_{ua} :** z-direction (in direction of anchor)
- Shear load $V_{ua,y}$:** y-direction (perpendicular to longitudinal axis of channel)
- Shear load $V_{ua,x}$:** x-direction (longitudinal with axis of channel)

FIGURE 2-1: LOAD DIRECTIONS COVERED BY THIS REPORT

The use is limited to cracked or uncracked normal weight and sand-lightweight concrete having a specified compressive strength, f_c , of 2,500 psi to 10,000 psi (17.2 MPa to 68.9 MPa) [minimum of 24 MPa is required under ADIBC Appendix L, Section 5.1.1].

Anchor channel systems are alternatives to cast-in-place anchors described in Section 1901.3 of the 2021, 2018 and 2015 IBC, Section 1908 and 1909 of the 2012 IBC, and Sections 1911 and 1912 of the 2009 and 2006 IBC. They may also be used where an engineered design is permitted in accordance with IRC Section R301.1.3.

3.0 DESCRIPTION

3.1 Jordahl anchor channel systems:

The Jordahl JTA, JXA, JXA-PC and JZA anchor channel systems (depicted in [Figure 8-1](#)) consist of an anchor channel profile, a minimum of two anchors, channel bolt(s) corresponding to the anchor channel, and matching nut(s) and washer(s) for the channel bolt(s). The Jordahl JTA anchor channels consist of a C-shaped carbon or stainless steel cold-formed (JTA K series) or hot-rolled (JTA W series) channel profile. The JXA and JZA anchor channels consist of a C-shaped carbon or stainless steel cold-formed (JZA K series) or hot-rolled (JXA W series) channel profile with serrated (toothed) channel lips. All channel profiles have at least two anchors that are factory-fixed to the channel back. Round headed anchors are forged (available on JTA K28/15, K38/17, W40/22, W40+, W50/30, W50+, W53/34, W55/42, and W72/48 profile sizes, JXA W29/20, W38/23 and W53/34 profile sizes, and JZA W41/22 profile sizes) or welded (available on JTA K28/15 and K38/17 profile sizes as well as JXA-PC W53/34 profile size) to the channel web (back). I-shaped and T-shaped anchors are welded (available on JTA W40/22, W40+, W50/30, W50+, W53/34 and W55/42 profile sizes, and JXA W38/23 W53/34, and W64/44 profile sizes) to the channel web (back). Deformed reinforcing bar anchors are welded (available on JTA W40/22, W50/30, W53/34, and W55/42 profile sizes) to the channel web (back). The maximum number of anchors per channel is not limited. The appropriate channel bolts and washers are placed in the anchor channel. The available channel bolts for the JTA channel profiles feature either a hammer-head (JD and JH) or a hook-head (JC, JKC, JB, JKB, and JA). The available channel bolts for the JXA, JXA-PC and JZA channel profiles feature matching serrations (JXD, JXH, JXB, JXE, and JZS).

The channel bolts are shown in [Figure 8-1](#) of this report. The available combinations of anchor channels and the corresponding channel bolts are given in [Tables 3](#) and [4](#) of this report. Washers required for standoff installations are given in [Table 22](#). Installation information and parameters are shown in [Figure 8-1](#) and [Figure 8-3](#), and are given in [Tables 1](#) and [2](#) of this report.

Steel specifications for the channels, anchors, channel bolts, and matching nuts and washers for the channel bolts are given in [Table 21](#) of this report. Hex nut and washer material type and grade must match the channel bolts.

3.2 Concrete:

Normal weight and sand-lightweight concrete must comply with Sections 1903 and 1905 of the IBC.

4.0 DESIGN AND INSTALLATION

4.1 Strength Design:

4.1.1 General: The design strength of anchor channel systems under the 2021, 2018, 2015, 2012, 2009, and 2006 IBC, must be determined in accordance with ACI 318-19 and -14 chapter 17, ACI 318-11, -08, and -05 Appendix D and this report.

4.1.2 Determination of forces acting on anchor channels:

4.1.2.1 General: Anchor channels shall be designed for critical effects of factored loads as determined by elastic analysis taking into account the elastic support by anchors and the partial restraint of the channel ends by concrete compression stresses. As an alternative, the load distribution method in accordance with Section 4.1.2.2, 4.1.2.3, and 4.1.2.4 to calculate the tension and shear loads on anchors shall be permitted. Design of adjacent anchor channels shall be in accordance with Section 4.1.2.6.

4.1.2.2 Tension loads: The tension loads, $N_{ua,i}^a$, on an anchor due to a tension load, N_{ua} , acting on the channel shall be computed in accordance with Eq. (1). An example for the calculation of the tension loads acting on the anchors is given in [Figure 4-1](#).

$$N_{ua,i}^a = k \cdot A'_i \cdot N_{ua} \quad (1)$$

Where

A'_i = ordinate at the position of the anchor i assuming a triangle with the unit height at the position of load N_{ua} and the base length $2\ell_{in}$ with ℓ_{in} determined in accordance with Eq. (3). Examples are provided in [Figure 4-1](#).

$$k = 1 / \sum A'_i \quad (2)$$

$$\ell_{in} = 4.93(I_y)^{0.05} \cdot \sqrt{s} \geq s, \text{ in.} \quad (3)$$

$$\ell_{in} = 13(I_y)^{0.05} \cdot \sqrt{s} \geq s, \text{ mm}$$

s = anchor spacing, in. (mm)

N_{ua} = factored tension load on channel bolt, lb (N)

I_y = the moment of inertia of the channel shall be taken from [Tables 1](#) and [2](#) of this report.

If several tension loads are simultaneously acting on the channel, a linear superimposition of the anchor forces for all loads shall be assumed. If the exact position of the load on the channel is not known, the most unfavorable loading position shall be assumed for each failure mode (e.g. load acting over an anchor for the case of failure of an anchor by steel rupture or pull-out and load acting between anchors in the case of bending failure of the channel).

The bending moment $M_{u,flex}$ on the channel due to tension loads acting on the channel shall be computed assuming a simply supported single span beam with a span length equal to the anchor spacing.

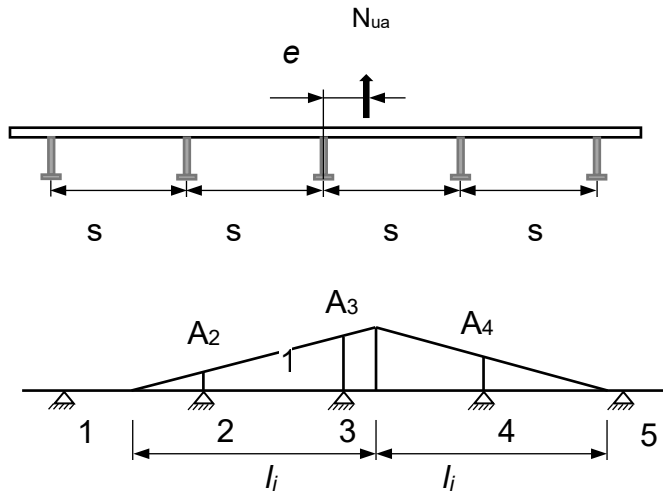

$$A_2 = \frac{l_i - e - s}{l_i} \quad A_3 = \frac{l_i - e}{l_i} \quad A_4 = \frac{l_i - s + e}{l_i}$$

$$l_i = 1.5 \cdot s \quad k = \frac{1}{A_2 + A_3 + A_4}$$

$$N_{ua,2}^a = A_2 \cdot k \cdot N_{ua}$$

$$N_{ua,3}^a = A_3 \cdot k \cdot N_{ua}$$

$$N_{ua,4}^a = A_4 \cdot k \cdot N_{ua}$$

$$N_{ua,1}^a = N_{ua,5}^a = 0$$

FIGURE 4-1: EXAMPLE FOR THE CALCULATION OF ANCHOR FORCES IN ACCORDANCE WITH THE TRIANGULAR LOAD DISTRIBUTION METHOD FOR AN ANCHOR CHANNEL WITH FIVE ANCHORS. THE INFLUENCE LENGTH IS ASSUMED AS $l_{IN} = 1.5S$

4.1.2.3 Shear loads acting on the channel perpendicular to its longitudinal axis: The shear load $V_{ua,y,i}$ on an anchor due to a shear load $V_{ua,y}$ acting on the channel perpendicular to its longitudinal axis shall be computed in accordance with Section 4.1.2.2 replacing N_{ua} in Eq. (1) by $V_{ua,y}$.

4.1.2.4 Shear loads acting on the channel longitudinal with the channel axis: The shear load $V_{ua,x,i}$ on an anchor due to a shear load $V_{ua,x}$ acting on the channel in the direction of the longitudinal channel axis shall be computed as follows:

For the verification of the strength of the anchor channel for failure of the anchor or failure of the connection between anchor and channel, pryout failure and concrete edge failure in case of anchor channels arranged parallel to the edge without corner effects, the shear load $V_{ua,x}$ shall be equally distributed to all anchors for anchor channels with not more than three anchors or to three anchors for anchor channels with more than three anchors (as illustrated in Figure 4-2). The shear load $V_{ua,x}$ shall be distributed to those three that result in the most unfavorable design condition (in the example given in Figure 4-2 the shear load $V_{ua,x}$ shall be distributed to the anchors 10 to 12).

For the verification of the strength of the anchor channel for concrete edge failure in case of anchor channels arranged perpendicular to the edge and in case of anchor channels arranged parallel to the edge with corner effects, the shear load $V_{ua,x}$, shall be equally distributed to all anchors for anchor channels with not more than three anchors or to the three anchors closest to the edge or corner for anchor channels with more than three anchors (as illustrated in Figure 4-3).

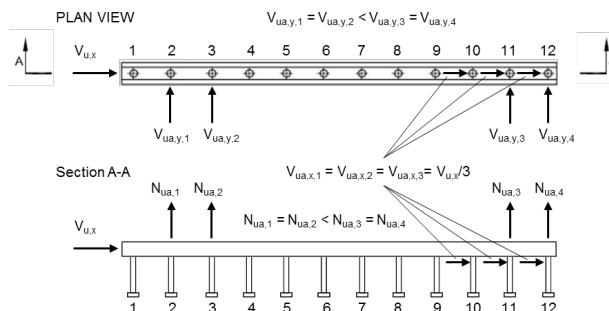

FIGURE 4-2: EXAMPLE FOR THE CALCULATION OF ANCHOR FORCES IN CASE OF ANCHOR CHANNELS WITH 12 ANCHORS LOADED IN SHEAR LONGITUDINAL TO THE CHANNEL AXIS FOR STEEL AND PRYOUT FAILURE

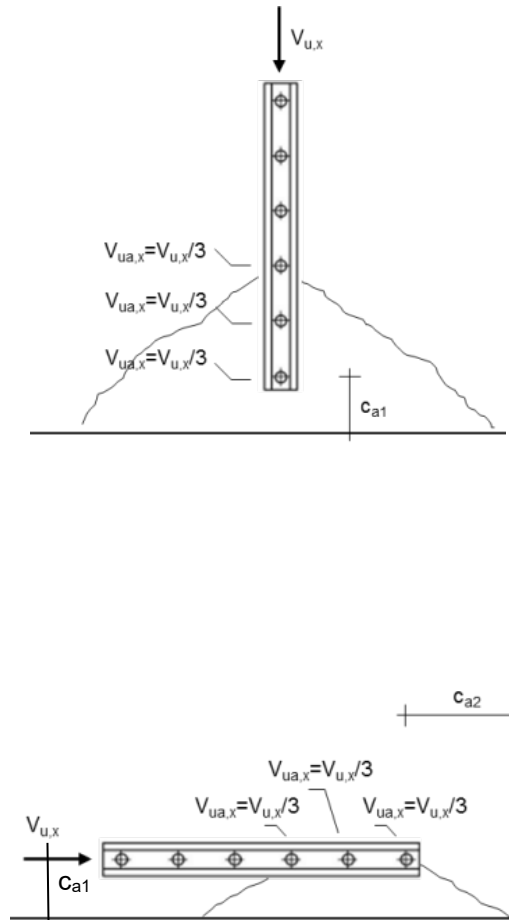

FIGURE 4-3: EXAMPLE FOR THE CALCULATION OF ANCHOR FORCES IN CASE OF ANCHOR CHANNELS WITH 6 ANCHORS LOADED IN SHEAR LONGITUDINAL TO THE CHANNEL AXIS FOR CONCRETE EDGE FAILURE

4.1.2.5 Forces related to anchor reinforcement: If tension loads are acting on the anchor channel, the factored tension forces of the anchor reinforcement for one anchor shall be computed for the factored tension load, $N_{ua,i}^0$, of the anchor assuming a strut-and-tie model.

If a shear load $V_{ua,y}$ is acting on the anchor channel, the resultant factored tension force of the anchor reinforcement $N_{ua,re}$, shall be computed by Eq. (4).

$$N_{ua,re} = V_{ua,y} \left(\frac{e_s}{z} + 1 \right) \quad , \text{ lb (N)} \quad (4)$$

where, as illustrated in [Figure 4-4](#)

e_s = distance between reinforcement and shear force acting on the anchor channel, in. (mm)

z = $0.85 \cdot (h - h_{ch} - 0.5d_a) \leq \min(2h_{ef}, 2c_{a1})$

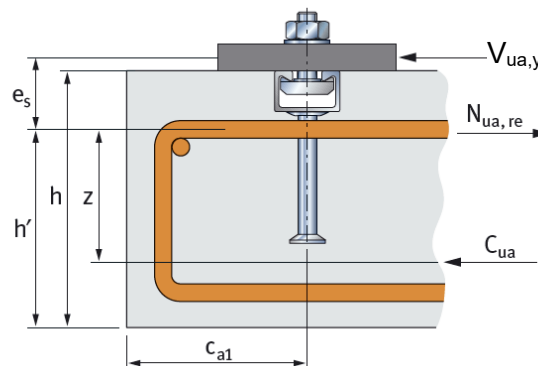

FIGURE 4-4: ANCHOR REINFORCEMENT TO RESIST SHEAR LOADS

4.1.2.6 Adjacent Anchor Channels: Anchor channels may be arranged as shown in [Figure 4-5](#). Adjacent anchor channels must be of same size and consist of anchors with same type and embedment depth. In case of anchor channel configurations according to [Figure 4-5b](#) and [Figure 4-5c](#) loaded in shear in any direction, the load shall be transferred to the adjacent anchor channels by a single plate (see [Figure 4-6](#)).

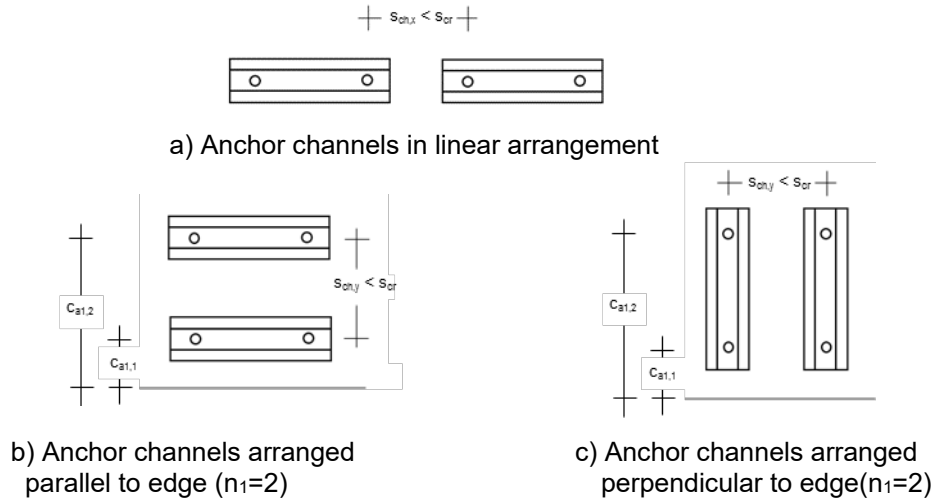

FIGURE 4-5—INCLUDED CONFIGURATIONS OF ADJACENT ANCHOR CHANNELS

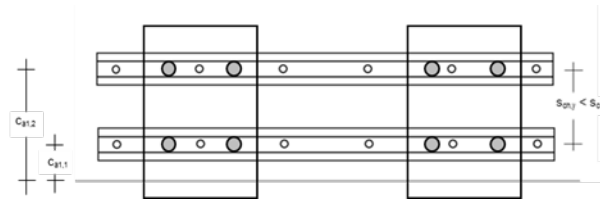

FIGURE 4-6—PERMISSIBLE CONFIGURATION WITH MULTIPLE ATTACHMENTS ($N_1 = 2$); TWO PLATES SHOWN. SHEAR TRANSFER BETWEEN ADJACENT ANCHOR CHANNELS BY ADJACENT PLATES.

4.1.3 Requirements for design strength:

4.1.3.1 General: The design strength of the anchor channel systems under the 2021 IBC as well as Section R301.1.3 of the 2021 IRC must be determined in accordance with ACI 318-19 Chapter 17 and this report.

The design strength of anchor channel systems under the 2018 and 2015 IBC as well as Section R301.1.3 of the 2018 and 2015 IRC must be determined in accordance with ACI 318-14 Chapter 17 and this report.

The design strength of anchor channel systems under the 2012 IBC as well as Section R301.1.3 of the 2012 IRC must be determined in accordance with ACI 318-11, Appendix D and this report.

The design strength of anchor channel systems under the 2009 IBC as well as Section R301.1.3 of the 2009 IRC must be determined in accordance with ACI 318-08 Appendix D and this report.

The design strength of anchor channel systems under the 2006 IBC as well as Section R301.1.3 of 2006 IRC must be determined in accordance with ACI 318-05 Appendix D and this report.

Design parameters provided in [Table 1](#) through [Table 18](#) in this report and references to ACI 318 are based on the 2021 IBC (ACI 318-19), 2018 and 2015 IBC (ACI 318-14) and the 2012 IBC (ACI 318-11) unless noted otherwise in Sections 4.1 and 4.2 of this report.

The strength design must comply with ACI 318-19 17.5.1.2, ACI 318-14 17.3.1 or ACI 318-11 D.4.1, as applicable, except as required in ACI 318-19 17.10, ACI 318-14 17.2.3 or ACI 318-11 D.3.3, as applicable.

Design parameters are provided in [Table 1](#) through [Table 18](#) of this report. Strength reduction factors, ϕ , as given in ACI 318-19 17.5.3, ACI 318-14 17.3.3, ACI 318-11 D.4.3, and in the tables of this report, as applicable, must be used for load combinations calculated in accordance with Section 1605.1 of the 2021 IBC, Section 1605.2 of the 2018, 2015, and 2012 IBC, Section 5.3 of ACI 318 (-19 or -14), or Section 9.2 of ACI 318-11, as applicable. Strength reduction factors, ϕ , as given in ACI 318-11 D.4.4 and in parentheses in the tables of this report must be used for load combinations calculated in accordance with ACI 318-11 Appendix C.

In Eq. (D-1), and (D-2) (ACI 318-05, -08), Table D.4.1.1 (ACI 318-11) or Table 17.3.1.1 (ACI 318-14) or Table 17.5.2 (ACI 318-19) ϕN_n and ϕV_n are the lowest design strengths determined from all appropriate failure modes. ϕN_n is the lowest design strength in tension of an anchor channel system determined from consideration of ϕN_{sa} , ϕN_{sc} , ϕN_{sl} , ϕN_{ss} , $\phi M_{s,flex}$, ϕN_{cb} , (anchor channels without anchor reinforcement to take up tension loads) or ϕN_{ca} (anchor channels with anchor reinforcement to take up tension loads), ϕN_{pn} , and ϕN_{sb} . $\phi V_{n,y}$ is the lowest design strength in shear perpendicular to the axis of an anchor channel as determined from $\phi V_{sa,y}$, $\phi V_{sc,y}$, ϕV_{ss} , $\phi V_{sl,y}$, $\phi V_{cb,y}$ (anchor channel without anchor reinforcement to take up shear loads perpendicular to the channel axis), or $\phi V_{ca,y}$ (anchor channel with anchor reinforcement to take up shear loads perpendicular to the channel axis) and $\phi V_{cp,y}$. $\phi V_{n,x}$ is the lowest design strength in shear acting longitudinal to the channel axis of an anchor channel as determined from $\phi V_{sa,x}$, $\phi V_{sc,x}$, ϕV_{ss} , $\phi V_{ss,M}$, $\phi V_{sl,x}$, $\phi V_{cb,x}$, (anchor channel without anchor reinforcement to take up shear loads), or $\phi V_{ca,x}$ (anchor channel with anchor reinforcement to take up shear loads) and $\phi V_{cp,x}$. The design strengths for all anchors of an anchor channel shall be determined.

4.1.3.2 Tension loads:

4.1.3.2.1 Required verifications: The following verifications are required:

- a. Steel Failure: Steel strength of anchor, strength of connection between anchor and channel, strength for local failure of channel lip, strength of channel bolt, bending strength of channel, see Section 4.1.3.2.2.
- b. Concrete breakout strength of anchor in tension, see Section 4.1.3.2.3.
- c. Pullout strength of anchor channel in tension, see Section 4.1.3.2.4.
- d. Concrete side-face blowout strength of anchor channel in tension, see Section 4.1.3.2.5.

4.1.3.2.2 Steel Strength in Tension: The nominal strength, N_{sa} , of a single anchor must be taken from [Tables 5](#) and [6](#) of this report.

The nominal strength, N_{sc} , of the connection between anchor and anchor channel must be taken from [Tables 5](#) and [6](#) of this report.

The nominal strength of the channel lips to take up tension loads transmitted by a channel bolt, N_{sl} , must be taken from [Tables 5](#) and [6](#) of this report. This value is valid only if the center-to-center distance between the channel bolt under consideration and adjacent channel bolts, s_{chb} , is at least $2b_{ch}$. If this requirement is not met then the value N_{sl} given in [Tables 5](#) and [6](#) must be reduced by the factor

$$1 + \sum_{i=2}^{n+1} \left[\left(1 - \frac{s_{chb,i}}{2b_{ch}} \right)^2 \cdot \frac{N_{ua,i}^b}{N_{ua,1}^b} \right] \quad (5)$$

where the center-to-center spacing between channel bolts shall not be less than three times the bolt diameter, d_s .

The nominal strength of the channel bolt, N_{ss} , must be taken from [Tables 15](#) and [16](#) of this report.

The nominal bending strength of the anchor channel, $M_{s,flex}$, must be taken from [Tables 5](#) and [6](#) of this report.

4.1.3.2.3 Concrete Breakout Strength in Tension: The nominal concrete breakout strength, N_{cb} , of a single anchor in tension of an anchor channel shall be determined in accordance with Eq. (6).

$$N_{cb} = N_b \cdot \psi_{s,N} \cdot \psi_{ed,N} \cdot \psi_{co,N} \cdot \psi_{c,N} \cdot \psi_{cp,N} \cdot l_b (N) \quad (6)$$

Where anchors consist of deformed reinforcing bars and the minimum spacing requirement in [Table 1](#) is met, verification for concrete breakout is not required provided that the reinforcing bars are lap spliced with reinforcing bars in the member according to the requirements of ACI 318-11 Section 12.14, ACI 318-14, -19 Section 25.5.

The basic concrete breakout strength of a single anchor in tension in cracked concrete, N_b , shall be determined in accordance with Eq. (7).

$$N_b = 24 \cdot \lambda \cdot \alpha_{ch,N} \cdot \sqrt{f'_c} \cdot h_{ef}^{1.5} \cdot l_b f \quad (7)$$

$$N_b = 10 \cdot \lambda \cdot \alpha_{ch,N} \cdot \sqrt{f'_c} \cdot h_{ef}^{1.5} \cdot N$$

where:

$$\alpha_{ch,N} = \left(\frac{h_{ef}}{7.1}\right)^{0.15} \leq 1 \quad (\text{inch-pound units})$$

$$\alpha_{ch,N} = \left(\frac{h_{ef}}{180}\right)^{0.15} \leq 1 \quad (\text{SI-units})$$

(8)

Where anchor channels with $h_{ef} > 7.1$ in. (180 mm) are located in an application with three or more edges (as illustrated in [Figure 4-7](#)) with edge distances less than $c_{cr,N}$ ($c_{cr,N}$ in accordance with Eq. (14)) from the anchor under consideration, the values of h_{ef} used in Eq. (7), (8), and (11) may be reduced to $h_{ef,red}$ in accordance with Eq. (9).

$$h_{ef,red} = \max\left(\frac{c_{a,max}}{c_{cr,N}} \cdot h_{ef} ; \frac{s}{s_{cr,N}} \cdot h_{ef}\right), \text{ in. (mm)} \quad (9)$$

where

$c_{a,max}$ is the maximum value of edge or corner distance, in. (mm)

The values $c_{cr,N}$ and $s_{cr,N}$ in Eq. (9) shall be computed with h_{ef} .

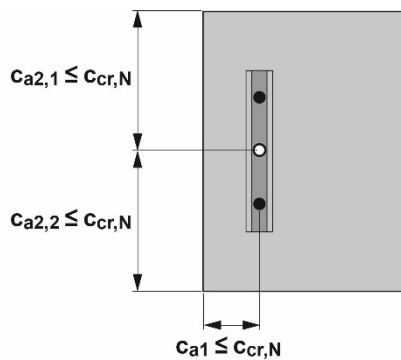

a) anchor channel with influence of one edge and two corners

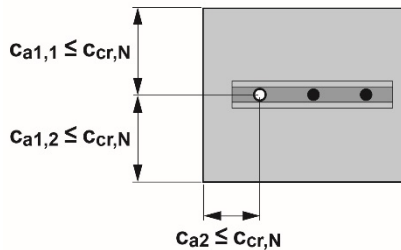

b) anchor channel with influence of two edges and one corner

○ anchor under consideration
● adjacent anchor

FIGURE 4-7: EXAMPLES OF ANCHOR CHANNEL LOCATIONS WHERE A REDUCED VALUE OF THE EMBEDMENT DEPTH, HEF,RED, MAY BE USED

The modification factor to account for the influence of location and loading of adjacent anchors, $\psi_{s,N}$, shall be computed in accordance with Eq. (10).

$$\psi_{s,N} = \frac{1}{1 + \sum_{i=2}^{n+1} \left[\left(1 - \frac{s_i}{s_{cr,N}}\right)^{1.5} \cdot \frac{N_{ua,i}^a}{N_{ua,1}^a} \right]} \quad (10)$$

where (as illustrated in [Figure 4-8](#))

s_i = distance between the anchor under consideration and adjacent anchor, in. (mm)
 $\leq s_{cr,N}$

$$s_{cr,N} = 2 \left(2.8 - \frac{1.3h_{ef}}{7.1} \right) h_{ef} \geq 3h_{ef}, \quad in. \quad (11)$$

$$s_{cr,N} = 2 \left(2.8 - \frac{1.3h_{ef}}{180} \right) h_{ef} \geq 3h_{ef}, \quad mm$$

$N_{ua,i}^a$ = factored tension load of an influencing anchor, lb (N)

$N_{ua,1}^a$ = factored tension load of the anchor under consideration, lb (N)

n = number of anchors of all anchor channels within a radial distance $s_{cr,N}$ from the anchor under consideration

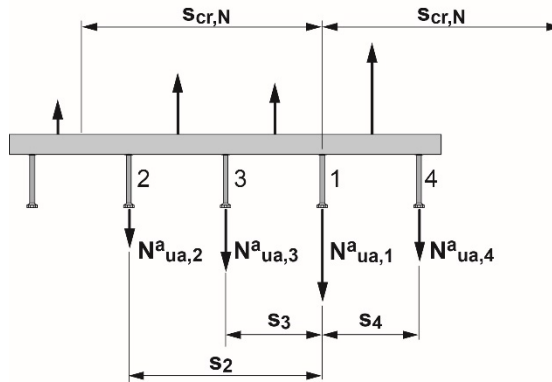

1 = anchor under consideration

2 to 4 = influencing anchors

FIGURE 4-8: EXAMPLE OF AN ANCHOR CHANNEL WITH NON-UNIFORM ANCHOR TENSION FORCES

The modification factor for edge effect of anchors loaded in tension, $\psi_{ed,N}$, shall be computed in accordance with Eq. (12) or (13).

If $c_{a1} \geq c_{cr,N}$ then $\psi_{ed,N} = 1.0$ (12)

If $c_{a1} < c_{cr,N}$ then $\psi_{ed,N} = (c_{a1} / c_{cr,N})^{0.5}$ (13)
 ≤ 1.0

where

$$c_{cr,N} = 0.5s_{cr,N} = \left(2.8 - \frac{1.3h_{ef}}{7.1} \right) h_{ef} \geq 1.5h_{ef}, \quad in. \quad (14)$$

$$c_{cr,N} = 0.5s_{cr,N} = \left(2.8 - \frac{1.3h_{ef}}{180} \right) h_{ef} \geq 1.5h_{ef}, \quad mm$$

If anchor channels are located in a narrow concrete member with multiple edge distances $c_{a1,1}$ and $c_{a1,2}$ (as shown in [Figure 4-9b](#)), the minimum value of $c_{a1,1}$ and $c_{a1,2}$ shall be inserted in Eq. (13).

The modification factor for corner effect for anchors loaded in tension, $\psi_{co,N}$, shall be computed in accordance with Eq. (15) or (16).

If $c_{a2} \geq c_{cr,N}$ then $\psi_{co,N} = 1.0$ (15)

If $c_{a2} < c_{cr,N}$ then $\psi_{co,N} = (c_{a2} / c_{cr,N})$ (16)
 $0.5 \leq 1.0$

where

c_{a2} = distance of the anchor under consideration to the corner (see [Figure 4-10a, b](#))

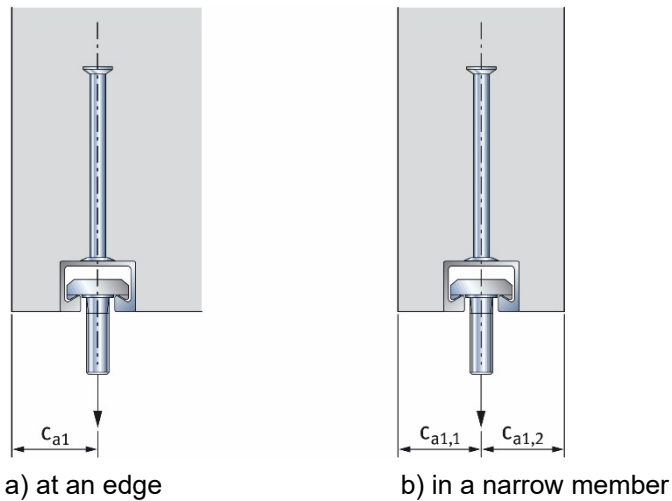

FIGURE 4-9: ANCHOR CHANNEL WITH EDGE(S)

If an anchor is influenced by two corners (as illustrated in Figure 4-10c), the factor $\psi_{co,N}$ shall be computed for each of the values $c_{a2,1}$ and $c_{a2,2}$ and the product of the factors, $\psi_{co,N}$, shall be inserted in Eq. (6).

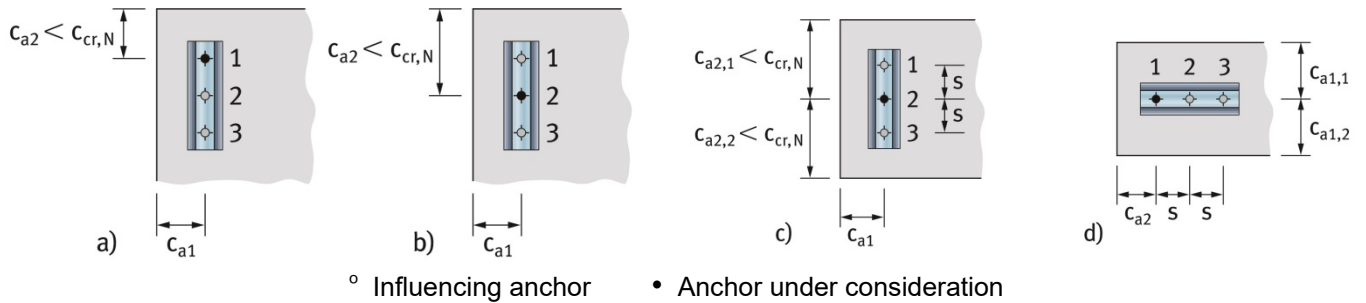

FIGURE 4-10: ANCHOR CHANNEL AT A CORNER OF A CONCRETE MEMBER

For anchor channels located in a region of a concrete member where analysis indicates no cracking at service load levels, the following modification factor shall be permitted:

$$\psi_{c,N} = 1.25$$

Where analysis indicates cracking at service load levels, $\psi_{c,N}$ shall be taken as 1.0. The cracking in the concrete shall be controlled by flexural reinforcement distributed in accordance with ACI 318-05, -08, -11 Section 10.6.4 or with ACI 318 (-14 or -19) Section 24.3.2 and 24.3.3, or equivalent crack control shall be provided by confining reinforcement.

The modification factor for anchor channels designed for uncracked concrete without supplementary reinforcement to control splitting, $\psi_{cp,N}$, shall be computed in accordance with Eq. (17) or (18). The critical edge distance, c_{ac} , shall be taken from Tables 7 and 8 of this report.

$$\text{If } c_{a,min} \geq c_{ac} \text{ then } \psi_{cp,N} = 1.0 \quad (17)$$

$$\text{If } c_{a,min} < c_{ac} \text{ then } \psi_{cp,N} = c_{a,min} / c_{ac} \quad (18)$$

whereby $\psi_{cp,N}$ as determined in accordance with Eq. (18) shall not be taken less than $c_{cr,N} / c_{ac}$, with $c_{cr,N}$ taken from Eq. (14).

For all other cases, $\psi_{cp,N}$ shall be taken as 1.0.

Where anchor reinforcement is developed in accordance with ACI 318-11 Chapter 12 or ACI 318 (-14 or -19) Chapter 25 on both sides of the breakout surface for an anchor of an anchor channel, the design strength of the anchor reinforcement, ϕN_{ca} , shall be permitted to be used instead of the concrete breakout strength, ϕN_{cb} , in determining ϕN_n . The anchor reinforcement for one anchor shall be designed for the tension force, N_{ua}^a on this anchor using a strut-and-tie model. The provisions in Figure 4-10 shall be taken into account when sizing and detailing the anchor reinforcement. Anchor reinforcement shall consist of stirrups made from deformed reinforcing bars with a maximum diameter of $5/8$ in. (No. 5 bar) (16 mm). A strength reduction factor, ϕ , of 0.75 shall be used in the design of the anchor reinforcement.

For anchor channels located parallel to the edge of a concrete member or in a narrow concrete member, the plane of the anchor reinforcement shall be arranged perpendicular to the longitudinal axis of the channel (as shown in [Figure 4-11](#)).

4.1.3.2.4 Pullout Strength in Tension: For anchors of anchor channels, the pullout strength N_{pn} shall be computed in accordance with D.5.3.1, D.5.3.4, and D.5.3.6 of ACI 318-05, -08, -11, Sections 17.4.3.1, 17.4.3.4, 17.4.3.6 of ACI 318-14, or Sections 17.6.3.1, 17.6.3.2.2(a), and 17.6.3.6 of ACI 318-19, as applicable.

4.1.3.2.5 Concrete Side-Face Blowout Strength of Anchor Channels in Tension: For anchor channels with deep embedment close to an edge ($h_{ef} > 2c_{a1}$) the nominal side-face blowout strength, N_{sb} , of a single anchor shall be computed in accordance with Eq. (19).

$$N_{sb} = N_{sb}^0 \cdot \psi_{s,Nb} \cdot \psi_{g,Nb} \cdot \psi_{co,Nb} \cdot \psi_{h,Nb} \cdot \psi_{c,Nb} \cdot lb(N) \quad (19)$$

The basic nominal strength of a single anchor without influence of neighboring anchors, corner or member thickness effects in cracked concrete, N_{sb}^0 , shall be computed in accordance with Eq. (20).

$$N_{sb}^0 = 128 \cdot \lambda \cdot c_{a1} \cdot \sqrt{A_{brg}} \cdot \sqrt{f'_c} \text{ ,lb.} \quad (20)$$

$$N_{sb}^0 = 10.5 \cdot \lambda \cdot c_{a1} \cdot \sqrt{A_{brg}} \cdot \sqrt{f'_c} \text{ ,N}$$

The modification factor accounting for the distance to and loading of neighboring anchors, $\psi_{s,Nb}$, shall be computed in accordance with Eq. (10), however $s_{cr,N}$ shall be replaced by $s_{cr,Nb}$, which shall be computed in accordance with Eq. (21).

$$s_{cr,Nb} = 4c_{a1} \text{ , in. (mm)} \quad (21)$$

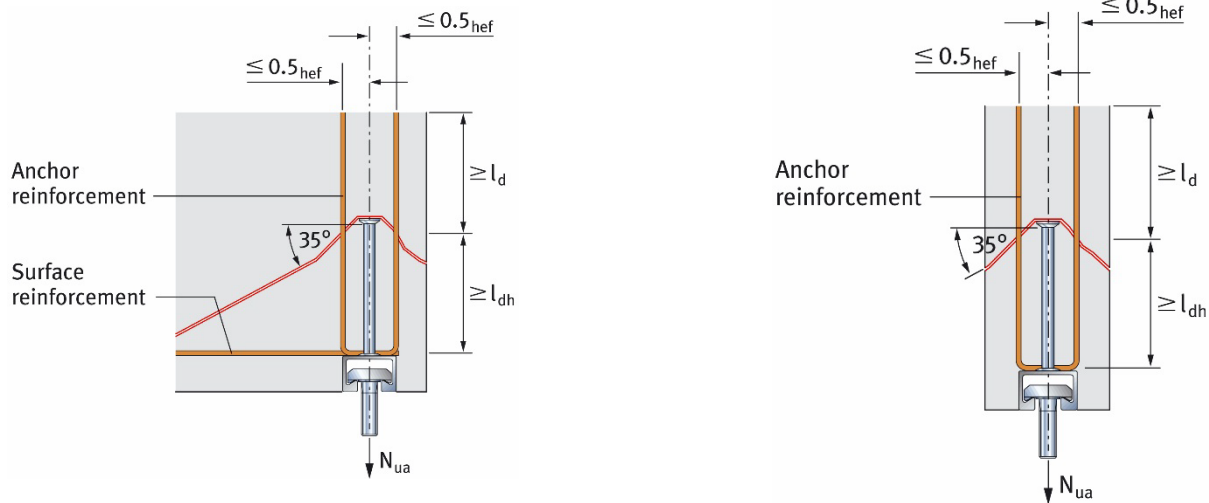

a) at an edge

b) in a narrow member

FIGURE 4-11: ARRANGEMENT OF ANCHOR REINFORCEMENT FOR ANCHOR CHANNELS LOADED BY TENSION LOAD

The modification factor to account for influence of the bearing area of neighboring anchors, $\psi_{g,Nb}$, shall be computed in accordance with Eq. (22) or Eq. (23).

$$\text{If } s \geq 4c_{a1} \text{ then } \psi_{g,Nb} = 1.0 \quad (22)$$

$$\text{If } s < 4c_{a1} \text{ then } \psi_{g,Nb} = \sqrt{n} + (1 - \sqrt{n}) \cdot \frac{s}{4c_{a1}} \geq 1.0 \quad (23)$$

where

n = number of tensioned anchors in a row parallel to the edge. For adjacent anchor channels, in Equation (23), s shall be taken as the maximum of the individual anchor spacing s and the spacing between end anchors in the adjacent anchor channels $s_{ch,x}$.

The modification factor to account for influence of corner effects, $\psi_{co,Nb}$, shall be computed in accordance with Eq. (24).

$$\psi_{co,Nb} = \left(\frac{c_{a2}}{c_{cr,Nb}} \right)^{0.5} \leq 1.0 \quad (24)$$

where

c_{a2} = corner distance of the anchor, for which the resistance is computed, in. (mm)

$$c_{cr,Nb} = 2c_{a1}, \text{ in. (mm)} \quad (25)$$

If an anchor is influenced by two corners ($c_{a2} < 2c_{a1}$), then the factor $\psi_{co,Nb}$ shall be computed for $c_{a2,1}$ and $c_{a2,2}$ and the product of the factors shall be inserted in Eq. (19).

The modification factor to account for influence of the member thickness, $\psi_{h,Nb}$ shall be computed in accordance with Eq. (26) or Eq. (27).

$$\text{If } f > 2c_{a1} \quad \text{then } \psi_{h,Nb} = 1.0 \quad (26)$$

$$\text{If } f \leq 2c_{a1} \quad \text{then } \psi_{h,Nb} = \frac{h_{ef} + f}{4c_{a1}} \leq \frac{2c_{a1} + f}{4c_{a1}} \quad (27)$$

where

f = distance between the anchor head and the surface of the concrete member opposite to the anchor channel (as illustrated in [Figure 4-12](#)), in. (mm)

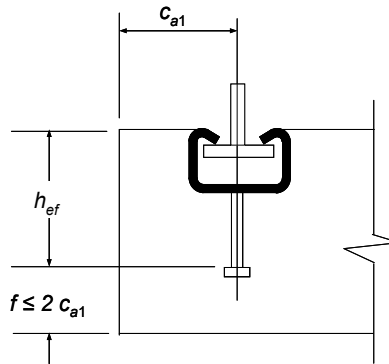

FIGURE 4-12: ANCHOR CHANNEL AT THE EDGE OF A THIN CONCRETE MEMBER

The following modification factor to account for influence of uncracked concrete, $\psi_{c,Nb}$, shall be permitted:

$$\psi_{c,Nb} = 1.25$$

For anchor channels located perpendicular to the edge and loaded uniformly, verification is only required for the anchor closest to the edge.

4.1.3.3 Shear loads acting on the channel system perpendicular to its longitudinal axis:

4.1.3.3.1 Required verifications: The following verifications are required:

- a. Steel Failure: Strength of channel bolt, strength of local failure of channel lip, strength of connection between anchor and channel, and strength of anchor, see Section 4.1.3.3.2.
- b. Concrete edge breakout strength of anchor channel in shear, see Section 4.1.3.3.3.
- c. Concrete pryout strength of anchor channel in shear, see Section 4.1.3.3.4.

4.1.3.3.2 Steel strength of anchor channel systems in shear perpendicular to its longitudinal axis: For anchor channel systems, the nominal steel shear strength shall be determined as follows:

The nominal strength of a channel bolt in shear, V_{ss} , must be taken from [Tables 17](#) and [18](#) of this report.

If the load is not applied at the concrete surface but to a fixture secured to the channel bolt as a stand-off connection at a distance from the concrete surface (e.g. by double nuts), the nominal strength of a channel bolt in shear, $V_{ss,M}$, shall be computed in accordance with Eq. (28). The use of a plate washer or fixture at the concrete surface is required for all installations, including installations using a stand off as noted above. See [Table 22](#) for minimum washer requirements.

$$V_{ss,M} = \frac{\alpha_M \cdot M_{ss}}{\ell} , \text{ lb (N)} \quad (28)$$

where

- α_M = factor to take into account the restraint condition of the fixture
- = 1.0 if the fixture can rotate freely (no restraint)
- = 2.0 if the fixture cannot rotate (full restraint)

$$M_{ss} = M_{ss}^0 \left(1 - \frac{N_{ua}}{\phi N_{ss}} \right), \text{ lb-in (N-mm)} \quad (29)$$

M_{ss}^0 = nominal flexural strength of channel bolt according to [Tables 17](#) and [18](#) of this report.

$$\leq 0.5N_{sl} \cdot a$$

$$\leq 0.5N_{ss} \cdot a$$

ℓ = lever arm, in. (mm)

a = internal lever arm, in. (mm) as illustrated in as in [Figure 4-13](#)

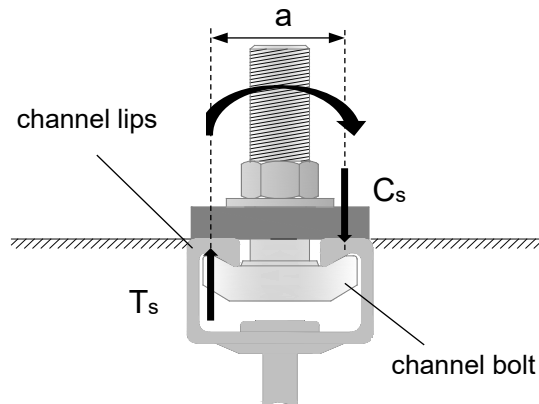

T_s = tension force acting on channel lips
 C_s = compression force acting on channel lips

FIGURE 4-13: DEFINITION OF INTERNAL LEVER ARM

The nominal strength of the channel lips to take up shear loads perpendicular to the channel transmitted by a channel bolt, $V_{sl,y}$, must be taken from [Tables 9](#) and [11](#) of this report.

The nominal strength of one anchor, $V_{sa,y}$, to take up shear loads perpendicular to the channel must be taken from [Tables 9](#) and [11](#) of this report.

The nominal strength of the connection between one anchor and the anchor channel, $V_{sc,y}$, to take up shear loads perpendicular to the channel must be taken from [Tables 9](#) and [11](#) of this report.

4.1.3.3.3 Concrete breakout strength of an anchor channel in shear perpendicular to its longitudinal axis: The nominal concrete breakout strength, $V_{cb,y}$, in shear perpendicular to the channel of a single anchor of an anchor channel in cracked concrete shall be computed as follows:

- a. For a shear force perpendicular to the edge by Eq. (30)

$$V_{cb,y} = V_b \cdot \psi_{s,V} \cdot \psi_{co,V} \cdot \psi_{c,V} \cdot \psi_{h,V}, \text{ lb (N)} \quad (30)$$

- b. For a shear force parallel to an edge (as shown in [Figure 4-14](#)), $V_{cb,y}$ shall be permitted to be 2.5 times the value of the shear force determined from Eq. (30) with the shear force assumed to act perpendicular to the edge.

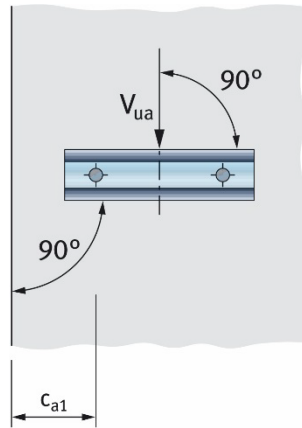

FIGURE 4-14: ANCHOR CHANNEL ARRANGED PERPENDICULAR TO THE EDGE AND LOADED PARALLEL TO THE EDGE

The basic concrete breakout strength in shear perpendicular to the channel of a single anchor of an anchor channel in cracked concrete, V_b , shall be computed in accordance with Eq. (31).

$$V_b = \lambda \cdot \alpha_{ch,V} \cdot \sqrt{f_c} \cdot c_{a1}^{4/3} \cdot lbf(N) \tag{31}$$

where:

$\alpha_{ch,V}$ = shall be taken from [Tables 13](#) and [14](#) of this report

f_c = the lesser of the specified concrete compressive strength and 8,500 psi (59 MPa)

The modification factor to account for the influence of location and loading of adjacent anchors, $\psi_{s,V}$ shall be computed in accordance with Eq. (32).

$$\psi_{s,V} = \frac{1}{1 + \sum_{i=2}^{n+1} \left[\left(1 - \frac{s_i}{s_{cr,V}} \right)^{1.5} \cdot \frac{V_{ua,i}^a}{V_{ua,1}^a} \right]} \tag{32}$$

where (as illustrated in [Figure 4-15](#))

s_i = distance between the anchor under consideration and the adjacent anchors

$$\leq s_{cr,V}$$

$$s_{cr,V} = 4c_{a1} + 2b_{ch}, \text{ in. (mm)} \tag{33}$$

$V_{ua,i}^a$ = factored shear load of an influencing anchor, lb (N)

$V_{ua,1}^a$ = factored shear load of the anchor under consideration, lb (N)

n = number of anchors of all anchor channels within a radial distance $s_{cr,V}$ from the anchor under consideration

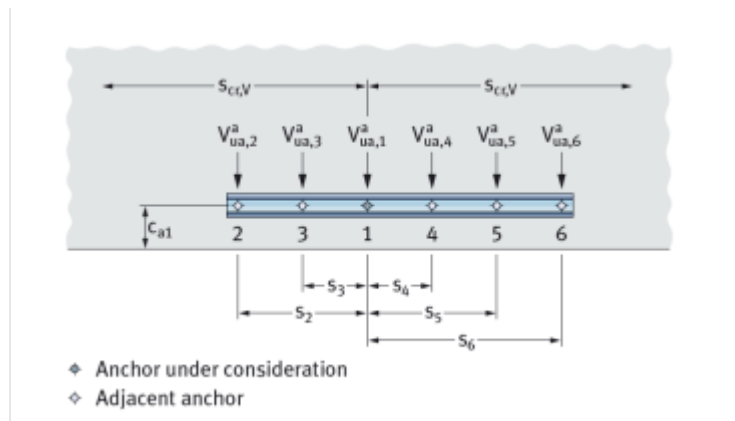

FIGURE 4-15: EXAMPLE OF AN ANCHOR CHANNEL WITH DIFFERENT ANCHOR SHEAR FORCES

The modification factor for corner effect for an anchor loaded in shear perpendicular to the channel, $\psi_{co,V}$, shall be computed in accordance with Eq. (34) or (35).

If $c_{a2} \geq c_{cr,V}$ then $\psi_{co,V} = 1.0$ (34)

If $c_{a2} < c_{cr,V}$ then $\psi_{co,V} = (c_{a2} / c_{cr,V})^{0.5}$ (35)

where

$c_{cr,V} = 2c_{a1} + b_{ch}$, in. (mm) (36)

If an anchor is influenced by two corners (as shown in [Figure 4-16b](#)), then the factor $\psi_{co,V}$ shall be computed for each corner in accordance with Eq. (34) or (35) and the product of the values of $\psi_{co,V}$ shall be inserted in Eq. (30).

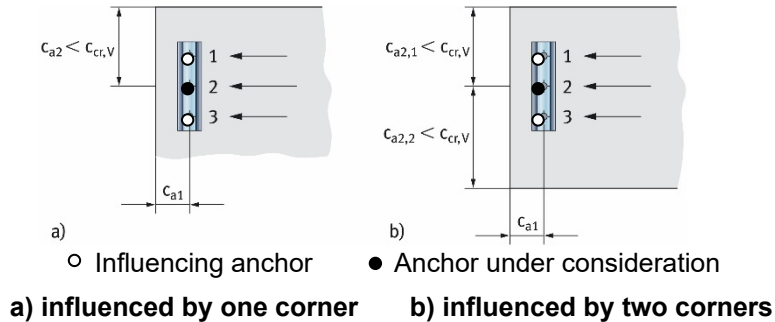

FIGURE 4-16: EXAMPLE OF AN ANCHOR CHANNEL LOADED IN SHEAR WITH ANCHORS:

For anchor channels located in a region of a concrete member where analysis indicates no cracking at service load levels, the following modification factor shall be permitted:

$\psi_{c,V} = 1.4$

For anchor channels located in a region of a concrete member where analysis indicates cracking at service load levels, the following modifications shall be permitted:

$\psi_{c,V} = 1.0$ for anchor channels in cracked concrete with no supplementary reinforcement

$\psi_{c,V} = 1.2$ for anchor channels in cracked concrete with edge reinforcement of a No. 4 bar (12.7 mm) or greater between the anchor channel and the edge in accordance with [Figure 4-17](#)

$\psi_{c,V} = 1.4$ for anchor channels in cracked concrete containing edge reinforcement with a diameter of 1/2 inch (12.7 mm) or greater (No. 4 bar or greater) between the anchor channel and the edge, and with the edge reinforcement enclosed within stirrups with a diameter of 1/2 inch (12.7 mm) or greater (No. 4 or greater) spaced 8 inches (200 mm) maximum.

The modification factor for anchor channels located in a concrete member with $h < h_{cr,V}$, $\psi_{h,V}$ (an example is given in [Figure 4-19](#)) shall be computed in accordance with Eq. (37).

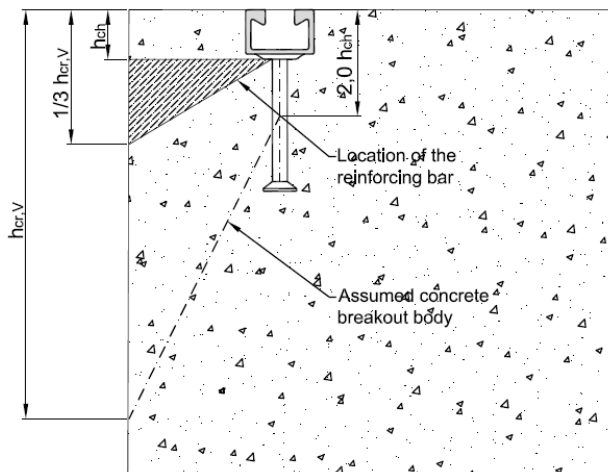

FIGURE 4-17—RECOMMENDED AREA FOR THE LOCATION OF THE EDGE REINFORCEMENT BAR (REINFORCING BAR LOCATION WITHIN RECOMMENDED AREA SHALL ACCOUNT FOR ALL FACTORS, (FOR EXAMPLE, CONCRETE COVER, BEND RADIUS, ETC.) AS REQUIRED BY ACI 318

$$\psi_{h,v} = \left(\frac{h}{h_{cr,v}} \right)^{\beta_1} \leq 1.0 \quad (37)$$

where

$$h_{cr,v} = 2c_{a1} + 2h_{ch}, \text{ in. (mm)} \quad (38)$$

$$\beta_1 = 0.5$$

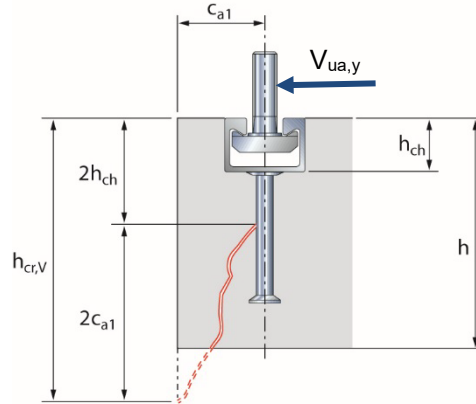
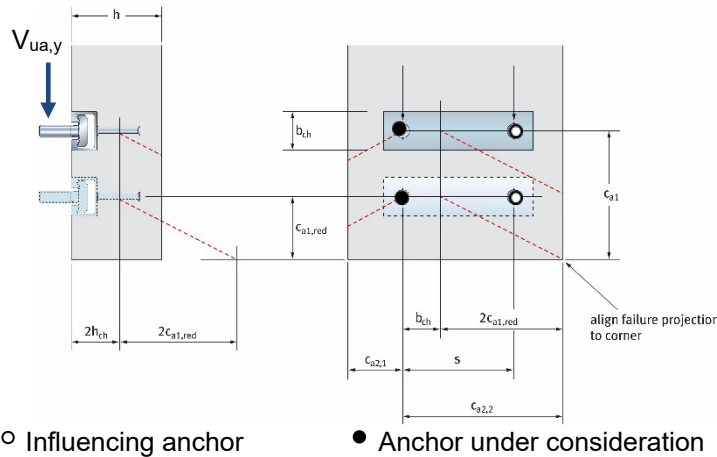

FIGURE 4-18: EXAMPLE OF AN ANCHOR CHANNEL IN A MEMBER WITH A THICKNESS $h < h_{cr,v}$

Where an anchor channel is located in a narrow member ($c_{a2,max} < c_{cr,v}$) with a thickness $h < h_{cr,v}$ (see [Figure 4-19](#)), the edge distance c_{a1} in Eq. (31), (33), (36) and (38) shall not exceed the value $c_{a1,red}$ determined in accordance with Eq. (39).

$$c_{a1,red} = \max \left[\frac{c_{a2,max} - b_{ch}}{2}; \frac{h - 2h_{ch}}{2} \right], \text{ in. (mm)} \quad (39)$$

where $c_{a2,max}$ is the largest of the edge distances perpendicular to the longitudinal axis of the channel.



○ Influencing anchor ● Anchor under consideration

For this example, the value of $c_{a1,red}$ is obtained by moving the failure surface forward until it intersects the corner as shown.

FIGURE 4-19: EXAMPLE OF AN ANCHOR CHANNEL INFLUENCED BY TWO CORNERS AND MEMBER THICKNESS (IN THIS EXAMPLE $c_{a2,2}$ IS DECISIVE FOR THE DETERMINATION OF $c_{a1,red}$)

For anchor channels with b_{ch} greater than 1.1 inches (28 mm) and h_{ch} greater than 0.6 inches (15 mm) arranged parallel to the edge and loaded by a shear load perpendicular to the edge and anchor reinforcement developed in accordance with ACI 318-11 Chapter 12 or ACI 318 (-14 or -19) Chapter 25 on both sides of the concrete surface, the design strength of the anchor reinforcement, $\phi V_{ca,y}$, shall be permitted to be used instead of the concrete breakout strength, $\phi V_{cb,y}$, in determining $\phi V_{n,y}$.

A strength reduction factor, ϕ , of 0.75 shall be used in the design of the anchor reinforcement. The strength of the anchor reinforcement assumed in design shall not exceed the value in accordance with Eq. (40). Only anchor reinforcement that complies with [Figure 4-20](#) shall be assumed as effective.

The maximum strength of the anchor reinforcement $V_{ca,y,max}$ of a single anchor of an anchor channel shall be computed in accordance with Eq. (40).

$$V_{ca,y,max} = \frac{2.85}{c_{a1}^{0.12}} \cdot V_{cb,y}, lb \tag{40}$$

$$V_{ca,y,max} = \frac{4.2}{c_{a1}^{0.12}} \cdot V_{cb,y}, N$$

where $V_{cb,y}$ is determined in accordance with Eq. (30).

Anchor reinforcement shall consist of stirrups made from deformed reinforcing steel bars with a maximum diameter of $\frac{5}{8}$ in. (15.9 mm) (No. 5 bar) and straight edge reinforcement with a diameter not smaller than the diameter of the stirrups (as shown in [Figure 4-20](#)). Only one bar at both sides of each anchor shall be assumed as effective. The distance of this bar from the anchor shall not exceed $0.5 c_{a1}$ and the anchorage length in the breakout body shall be not less than 4 times the bar diameter. The distance between stirrups shall not exceed the smaller of anchor spacing or 6 inches (152 mm).

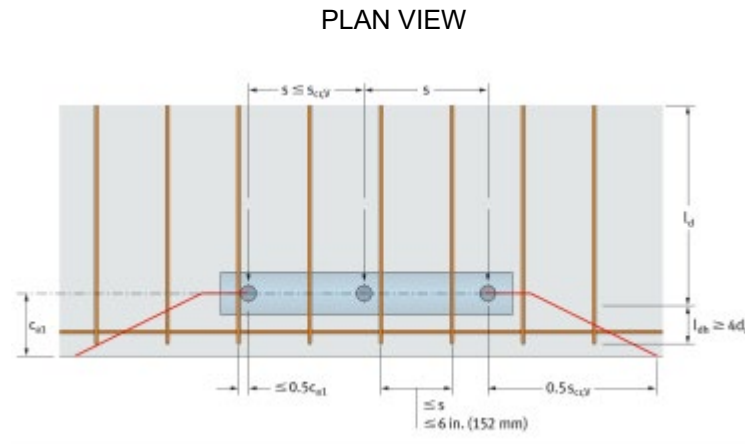

FIGURE 4-20: REQUIREMENTS FOR DETAILING OF ANCHOR REINFORCEMENT OF ANCHOR CHANNELS

The anchor reinforcement of an anchor channel shall be designed for the highest anchor load, $V_{ua,y}^a$, of all anchors, but at least for the highest individual shear load, $V_{ua,y}^b$, acting on the channel. This anchor reinforcement shall be arranged at all anchors of an anchor channel.

4.1.3.3.4 Concrete pryout strength of anchor channels in shear perpendicular to the channel axis: The nominal pryout strength, $V_{cp,y}$, in shear of a single anchor of an anchor channel without anchor reinforcement shall be computed in accordance with Eq. (41).

$$V_{cp,y} = k_{cp} \cdot N_{cb}, lb (N) \tag{41}$$

where

k_{cp} = shall be taken from [Tables 13](#) and [14](#)

N_{cb} = nominal concrete breakout strength of the anchor under consideration, lb (N), determined in accordance with Section 4.1.3.2.3; however in the determination of the modification factor $\psi_{s,N}$, the values $N_{ua,1}^a$ and $N_{ua,i}^a$ in Eq. (10) shall be replaced by $V_{ua,1}^a$ and $V_{ua,i}^a$, respectively.

The nominal pryout strength, $V_{cp,y}$, in shear of a single anchor of an anchor channel with anchor reinforcement shall not exceed:

$$V_{cp,y} = 0.75 \cdot k_{cp} \cdot N_{cb}, lb (N) \tag{42}$$

with k_{cp} and N_{cb} as defined above.

4.1.3.4 Shear loads acting on the channel system longitudinal with the channel axis:**4.1.3.4.1 Required verifications:** The following verifications are required:

- a. Steel Failure: Strength of channel bolt, strength of local failure of channel lip, strength of connection between anchor and channel, and strength of anchor, see Section 4.1.3.4.2.
- b. Concrete edge breakout strength of anchor channel in shear, see Section 4.1.3.4.3.
- c. Concrete pryout strength of anchor channel in shear, see Section 4.1.3.4.4.

4.1.3.4.2 Steel strength of anchor channel systems in shear longitudinal with the channel axis: For anchor channels, the nominal steel shear strength shall be determined as follows:

The nominal strength of a channel bolt in shear, V_{ss} , shall be taken from [Tables 16](#) and [17](#) of this report.

If the load is not applied at the concrete surface but to a fixture secured to the channel bolt as a stand-off connection at a distance from the concrete surface (e.g. by double nuts), the nominal strength of a channel bolt in shear, $V_{ss,M}$, shall be computed in accordance with Eq. (28).

The nominal strength of the channel lips to take up shear loads in direction of the longitudinal channel axis transmitted by a channel bolt, $V_{sl,x}$, shall be taken from [Tables 10](#) and [12](#) of this report.

The nominal strength of one anchor, $V_{sa,x}$, to take up shear loads perpendicular to the channel axis shall be taken from [Tables 10](#) and [12](#) of this report.

The nominal strength of the connection between one anchor and the anchor channel, $V_{sc,x}$, to take up shear loads longitudinal to the channel axis shall be taken from [Tables 10](#) and [12](#) of this report.

4.1.3.4.3 Concrete breakout strength of anchor channels in shear longitudinal with the channel axis:

The nominal concrete breakout strength, $V_{cb,x}$, in shear in direction of the longitudinal channel axis of a single anchor of an anchor channel in cracked concrete shall be computed as follows:

- a) For a shear force perpendicular to the edge, by Eq. (30). The basic concrete breakout strength in shear in direction of the longitudinal channel axis of a single anchor of an anchor channel in cracked concrete, V_b , shall be computed in accordance with Eq. (31).
- b) For a shear force parallel to an edge, $V_{cb,x}$, shall be permitted to be twice the value of the shear force determined from Eq. (30) with the shear force assumed to act perpendicular to the edge.

For I-shaped anchors, the value of d_a shall be taken as the web thickness and the edge distance c_{a1} , shall be taken from the leading edge of the anchor.

For anchor channels in parallel configuration, it shall be permitted to calculate the concrete breakout strength either for the anchor channel closest to the edge or the anchor channel furthest from the edge. The nominal concrete breakout strength shall be computed as follows:

- a) For verification of the anchor channel closest to the edge, the nominal concrete breakout strength shall be calculated according to Eq. (43).

$$V_{cb} = \min(n_{ch} \cdot V_{cb}(c_{a1,1}); V_{cb}(c_{a1,n})), lb (N) \quad (43)$$

- b) For verification of the anchor channel furthest from the edge, the nominal concrete breakout strength shall be calculated according to Eq. (44).

$$V_{cb} = V_{cb}(c_{a1,n}), lb (N) \quad (44)$$

4.1.3.4.4 Concrete pryout strength of anchor channels in shear longitudinal with the channel axis: The nominal pryout strength, $V_{cp,x}$, in shear of a single anchor of an anchor channel without anchor reinforcement shall be computed in accordance with Eq. (41).

The nominal pryout strength, $V_{cp,x}$, in shear of a single anchor of an anchor channel with anchor reinforcement shall not exceed Eq. (42).

4.1.3.4.5 Requirements for seismic design: Anchor channel systems shall be designed according to D.3.3.5 (ACI 318-05), or D.3.3.5 or D.3.3.6 (ACI 318-08).

The design of channel systems to resist tension loads in SDC C, D, E or F where D.3.3.4.2 (ACI 318-11) or 17.2.3.4.2 (ACI 318-14) or 17.10.5.1 (ACI 318-19) applies shall satisfy the requirements of D.3.3.4.3 (b), (c) or (d) (ACI 318-11) or 17.2.3.4.3 (b), (c) or (d) (ACI 318-14) or 15.5.3 (b), (c), or (d) (ACI 318-19), as applicable.

The design of anchor channel systems to resist shear loads in SDC C, D, E or F where D.3.3.5.2 (ACI 318-11) or 17.2.3.5.2 (ACI 318-14) or 17.10.6.2 (ACI 318-19) applies shall satisfy the requirements of D.3.3.5.3 (ACI 318-11) or 17.2.3.5.3 (ACI 318-14), or 17.10.6.3 (ACI 318-19), respectively.

For anchor channel systems in SDC C, D, E or F, the design strengths given in Section 4.1.3.1 through Section 4.1.3.4 shall be taken as the corresponding seismic strengths $\phi N_{n,seis}$, $\phi V_{n,y,seis}$ and $\phi V_{n,x,seis}$.

4.1.3.5 Interaction of tensile and shear forces: If forces act in more than one direction, the combination of loads has to be verified.

Anchor channel systems subjected to combined axial and shear loads shall be designed to satisfy the following requirements by distinguishing between steel failure of the channel bolt, steel failure modes of the channel and concrete failure modes.

4.1.3.5.1 Steel failure of channel bolts under combined loads: For channel bolts, Eq. (45) shall be satisfied.

$$\left(\frac{N_{ua}^b}{\phi N_{ss}^b} \right)^2 + \left(\frac{V_{ua}^b}{\phi V_{ss}^b} \right)^2 \leq 1.0 \quad (45)$$

$$\text{with } V_{ua}^b = \sqrt{(V_{ua,x}^b)^2 + (V_{ua,y}^b)^2}$$

where N_{ua}^b is the factored tension load, $V_{ua,y}^b$ is the factor shear load in perpendicular direction, and $V_{ua,x}^b$ is the factored shear load in longitudinal direction to the channel axis on the channel bolt under consideration.

This verification is not required in case of shear load with lever arm as Eq. (28) accounts for the interaction.

4.1.3.5.2 Steel failure modes of anchor channel systems under combined loads: For steel failure modes of anchor channel systems Eq. (46), Eq. (47) and Eq. (48) shall be satisfied.

a. For anchor and connection between anchor and channel:

$$\max \left(\frac{N_{ua}^a}{\phi N_{sa}^a}; \frac{N_{ua}^a}{\phi N_{sc}^a} \right)^\alpha + \max \left(\frac{V_{ua,y}^a}{\phi V_{sa,y}^a}; \frac{V_{ua,y}^a}{\phi V_{sc,y}^a} \right)^\alpha \quad (46)$$

$$+ \max \left(\frac{V_{ua,x}^a}{\phi V_{sa,x}^a}; \frac{V_{ua,x}^a}{\phi V_{sc,x}^a} \right)^2 \leq 1.0$$

where

$\alpha = 2$ for anchor channels with $\max(V_{sa,y}; V_{sc,y}) \leq \min(N_{sa}; N_{sc})$

$\alpha = 1$ for anchor channels with $\max(V_{sa,y}; V_{sc,y}) > \min(N_{sa}; N_{sc})$

It shall be permitted to assume reduced values for $V_{sa,y}$ and $V_{sc,y}$ corresponding to the use of an exponent $\alpha = 2$. In this case the reduced values for $V_{sa,y}$ and $V_{sc,y}$ shall also be used in Section 4.1.3.3.1a.

b. At the point of load application:

$$\left(\frac{N_{ua}^b}{\phi N_{sl}^b} \right)^\alpha + \left(\frac{V_{ua,y}^b}{\phi V_{sl,y}^b} \right)^\alpha + \left(\frac{V_{ua,x}^b}{\phi V_{sl,x}^b} \right)^2 \leq 1.0 \quad (47)$$

$$\left(\frac{M_{u,flex}}{\phi M_{s,flex}} \right)^\alpha + \left(\frac{V_{ua,y}^b}{\phi V_{sl,y}^b} \right)^\alpha + \left(\frac{V_{ua,x}^b}{\phi V_{sl,x}^b} \right)^2 \leq 1.0 \quad (48)$$

where

$\alpha = 2$ for anchor channels with $V_{sl,y} \leq N_{s,l}$

$\alpha = 1$ for anchor channels with $V_{sl,y} > N_{s,l}$

Concrete failure modes of anchor channels under combined loads: For concrete failure modes, anchor channels shall be designed to satisfy the requirements in a) through d).

$$\text{a) If } \left(\frac{V_{ua,y}^a}{\phi V_{nc,y}^a} \right) + \left(\frac{V_{ua,x}^a}{\phi V_{nc,x}^a} \right) \leq 0.2$$

then the full strength in tension shall be permitted: $\phi N_{nc} \geq N_{ua}^a$

$$\text{b) If } N_{ua}^a \leq 0.2\phi N_{nc} \text{ then the full strength in shear shall be permitted: } \left(\frac{V_{ua,y}^a}{\phi V_{nc,y}^a} \right) + \left(\frac{V_{ua,x}^a}{\phi V_{nc,x}^a} \right) \leq 1.0$$

c) If $\left(\frac{V_{ua,y}^a}{\phi V_{nc,y}}\right) + \left(\frac{V_{ua,x}^a}{\phi V_{nc,x}}\right) > 0.2$ and $N_{ua}^a > 0.2\phi N_{nc}$

then Eq. (49) applies

$$\left(\frac{N_{ua}^a}{\phi N_{nc}}\right) + \left(\frac{V_{ua,y}^a}{\phi V_{nc,y}}\right) + \left(\frac{V_{ua,x}^a}{\phi V_{nc,x}}\right) \leq 1.2 \quad (49)$$

d) Alternatively, instead of satisfying the requirements in a) through c), the interaction Eq. (50) shall be satisfied:

$$\left(\frac{N_{ua}^a}{\phi N_{nc}}\right)^{5/3} + \left(\frac{V_{ua,y}^a}{\phi V_{nc,y}}\right)^{5/3} + \left(\frac{V_{ua,x}^a}{\phi V_{nc,x}}\right)^{5/3} \leq 1.0 \quad (50)$$

Where anchors consist of deformed reinforcing bars in accordance with Section 3.1, and the deformed reinforcing bars are lap spliced with reinforcing bars in the member according to the requirements of ACI 318-08 or ACI 318-11 Section 12.14, or ACI 318-14 or ACI 318-19 Section 25.5, the interaction equation (51) shall be satisfied.

$$\left(\frac{V_{ua,y}^a}{\phi V_{nc,y}}\right)^{5/3} + \left(\frac{V_{ua,x}^a}{\phi V_{nc,x}}\right)^{5/3} \leq \alpha \quad (51)$$

where

a = 0.9 for anchor channels with deformed reinforcing bars not bonded

a = 1.0 for anchor channels with deformed reinforcing bars debonded underneath the channel profile for a length of 2 in. (50 mm)

4.1.4 Minimum Member Thickness, Anchor Spacing, and Edge Distance: Anchor channels shall satisfy the requirements for edge distance, spacing, and member thickness.

The minimum edge distance, minimum and maximum anchor spacing and minimum member thickness shall be taken from [Tables 1](#) and [2](#) of this report. The critical edge distance, c_{ac} , shall be taken from [Tables 7](#) and [8](#) of this report.

4.1.5 Requirement for lightweight concrete: For the use of anchor channels in sand-lightweight concrete, the modification factor λ shall be taken as 0.85 for sand-lightweight concrete.

4.2 Allowable Stress Design:

4.2.1 General: Strength design values determined in accordance with ACI 318 (-05, -08, -11) Appendix D or ACI 318 (-14 or -19) Chapter 17, as applicable, with amendments in Section 4.1 of this report, may be converted to values suitable for use with allowable stress design (ASD) load combinations. Such guidance of conversions shall be in accordance with the following:

For anchor channel systems designed using load combinations in accordance with 2021 IBC Section 1605.1, or 2018, 2015, or 2012 IBC Section 1605.3 (Allowable Stress Design), allowable loads shall be established using Eq. (52), Eq. (53), Eq. (54) and Eq. (55).

$$T_{allowable,ASD} = \frac{\phi N_n}{\alpha_{ASD}} \quad (52)$$

$$V_{x,allowable,ASD} = \frac{\phi V_{n,x}}{\alpha_{ASD}} \quad (53)$$

$$V_{y,allowable,ASD} = \frac{\phi V_{n,y}}{\alpha_{ASD}} \quad (54)$$

$$M_{s,flex,allowable,ASD} = \frac{\phi M_{s,flex}}{\alpha_{ASD}} \quad (55)$$

where

$T_{allowable,ASD}$ = Allowable tension load, lb (N)

$V_{x,allowable,ASD}$ = Allowable shear load longitudinal with the channel axis, lb (N)

$V_{y,allowable,ASD}$ = Allowable shear load perpendicular to the channel axis, lb (N)

$M_{s,flex,allowable,ASD}$ = Allowable bending moment due to tension loads lb-in (Nm)

- $\phi N_n =$ Lowest design strength of an anchor, channel bolt, or anchor channel in tension for controlling failure mode as determined in accordance with ACI 318 (-05, -08, -11) Appendix D or ACI 318 (-14 or -19) Chapter 17 as applicable with amendments in Section 4.1 of this report, lb (N).
- $\phi V_{n,x} =$ Lowest design strength of an anchor, channel bolt, or anchor channel in shear longitudinal with the channel axis for controlling failure mode as determined in accordance with ACI 318 (-05, -08, -11) Appendix D or ACI 318 (-14 or -19) Chapter 17 as applicable with amendments in Section 4.1 of this report, lb (N).
- $\phi V_{n,y} =$ Lowest design strength of an anchor, channel bolt, or anchor channel in shear perpendicular to the channel axis for controlling failure mode as determined in accordance with ACI 318 (-05, -08, -11) Appendix D or ACI 318 (-14 or -19) Chapter 17 as applicable with amendments in Section 4.1 of this report, lb (N).
- $\alpha_{ASD} =$ Conversion factor calculated as a weighted average of the load factors for the controlling load combination. In addition, α_{ASD} shall include all applicable factors to account for non-ductile failure modes and required overstrength.

4.2.2 Interaction of tensile and shear forces: Interaction shall be calculated in accordance with Section 4.1.3.4 and amendments in Section 4.1 of this report.

N_{ua} , $V_{ua,x}$, $V_{ua,y}$ and $M_{u,flex}$ shall be replaced by the unfactored loads T^a , V_x^a , V_y^a and M^a . The design strengths ϕN_n , $\phi V_{n,x}$, $\phi V_{n,y}$ and $\phi M_{s,flex}$ shall be replaced by the allowable loads $T_{allowable,ASD}$, $V_{x,allowable,ASD}$, $V_{y,allowable,ASD}$ and $M_{s,flex,allowable,ASD}$.

where

- $T^a =$ unfactored tension load applied to an anchor channel system, lb (N)
- $M^a =$ unfactored bending moment on anchor channel due to tension loads (calculation according to Section 4.1.2.2, lb-in (Nm))
- $V_x^a =$ unfactored shear load applied to an anchor channel system longitudinal with the channel axis, lb (N)
- $V_y^a =$ unfactored shear load applied to an anchor channel system perpendicular to the channel axis, lb (N)

4.3 Installation:

Installation parameters are provided in [Tables 1](#) and [2](#) of this report. Anchor channel location must comply with this report and the plans and specifications approved by the code official. Installation of the anchor channel systems must conform to the manufacturer's printed installation instructions (MPII) included with the product, as provided in [Figure 8-3](#). Minimum end distance for cutting anchor channels shall be in accordance with the minimum end spacing, x_{min} , listed in [Tables 1](#) and [2](#) of this report.

Channel installation in formwork includes the following steps according to [Figure 8-3](#):

1. Install the channel surface flush and fix the channel securely to the formwork or to the reinforcement.
 - 1a. Fixing to steel formwork: With Jordahl channel bolts and nuts, with rivets, clamps, or magnetic fixings, or
 - 1b. Fixing to timber formwork: With nails through the pre-punched holes in the back of the channels or with staples, or
 - 1c. Fixing to the anchor channels at the top: To timber battens on the side formwork (e.g. with Jordahl channel bolts); or fixing from above directly to the reinforcement; or fixing to a rebar by wire tying.
2. Pouring concrete and regular compacting of concrete. Compact the concrete properly around the channel and the anchors, around the sidefaces to the formwork (2a), in soffits (2b), and into top surfaces of concrete up stands (2c).
3. After hardening of concrete, remove the channel foam infill. Clean the channel on the outside after removing the formwork. Clean the foam infill with the claw of a hammer or a hook (3a), or clean the polyethylene-foam infill in one piece by hand or with the help of a screwdriver (3b).
4. Fastening the Jordahl channel bolt to the anchor channel for (a) the general application (fixture in contact with concrete):
 - i. Insert the Jordahl channel bolt into the channel slot at any point along the channel length.
 - ii. Turn the channel bolt 90 degrees clockwise and the head of the bolt will lock into position.

- iii. Do not mount the channel bolt at the end of the channel within the end distance x_{min} according to [Tables 1](#) and [2](#).
- iv. Install the fixture. Use a washer under the nut.
- v. Check the correct fit of the Jordahl channel bolt. The groove on the shank end of the channel bolt must be perpendicular to the channel longitudinal axis.
- vi. Tighten the nuts by a calibrated torque wrench to the setting torque according to [Table 19](#) for general installation. The setting torque shall not be exceeded.

Fastening the Jordahl channel bolt to the anchor channel for (b) steel-to-steel contact (fixture in contact with the anchor channel only):

- i. Insert the Jordahl channel bolt into the channel slot at any point along the channel length.
- ii. Turn the channel bolt 90 degrees clockwise and the head of the bolt will lock into position.
- iii. Do not mount the channel bolt at the end of the channel within the end distance x_{min} according to [Tables 1](#) and [2](#).
- iv. Use washers between channel and fixture to avoid bearing of the fixture against the concrete.
- v. Install the fixture. Use a washer under the nut.
- vi. Check the correct fit of the Jordahl channel bolt. The groove on the shank end of the channel bolt must be perpendicular to the channel longitudinal axis.
- vii. Tighten the nuts by a calibrated torque wrench to the setting torque according to [Table 20](#) for steel-to-steel contact. The setting torque must not be exceeded. Channel bolts JKB and JKC must only be used once; removal and reinstallation of the same channel bolts is not allowed.

4.4 Special Inspection:

Periodic special inspection shall be performed as required in accordance with Section 1705.1.1 and Table 1705.3 of the 2021, 2018, 2015 and 2012 IBC, Section 1704.15 of the 2009 IBC or Section 1704.13 of the 2006 IBC and in accordance with this report.

Inspection requirements:

Prior to concrete placement, the special inspector shall inspect the placement of anchor channels in the formwork to verify anchor channel type, channel size, anchor type, number of anchors, anchor size, and length of anchors, as well as anchor channel location, position, orientation, and edge distance in accordance with the construction documents. The special inspector shall also verify that anchor channels are secured within the formwork in accordance with the manufacturer's printed installation instructions (MPII).

Following placement of concrete and form removal, the special inspector shall verify that the concrete around the anchor channel is without significant visual defects, that the anchor channel is flush with the concrete surface, and that the channel interior is free of concrete, laitance, or other obstructions. When anchor channels are not flush with the concrete surface, the special inspector shall verify that appropriate sized shims are provided in accordance with the MPII. Following the installation of attachments to the anchor channel, the special inspector shall verify that the specified system hardware, such as T-headed channel bolts and washers, have been used and positioned correctly, and the installation torque has been applied to the channel bolts in accordance with the installation instructions (MPII). For the JTA channel systems (non-serrated) in combination with JA, JB, JC, JH or JD bolts, the special inspector shall confirm with the engineer of record that the attachments do not produce gravity, wind, and/or seismic loading parallel to the longitudinal axis of the channel (see [Figure 2-1](#)).

The special inspector shall be present for the installations of attachments to each type and size of anchor channel.

Where they exceed the requirements stated here, the special inspector shall adhere to the special inspection requirements provided in the statement of special inspections as prepared by the registered design professional in responsible charge.

Proof loading program:

Where required by the registered design professional in responsible charge, a program for on-site proof loading (proof loading program) to be conducted as part of the special inspection shall include at a minimum the following information:

1. Frequency and location of proof loading based on channel size and length;
2. Proof loads specified by channel profile size and channel bolt;
3. Acceptable displacements at proof load;
4. Remedial action in the event of failure to achieve proof load or excessive displacement.

5.0 CONDITIONS OF USE:

The Jordahl JTA, JXA, JXA-PC and JZA anchor channel systems described in this report are suitable alternatives to what is specified in the codes listed in Section 1.0 of this report, subject to the following conditions:

- 5.1 The Jordahl JTA, JXA, JXA-PC and JZA anchor channel systems must be installed in accordance with the manufacturer's printed installation instructions (MPII) and this report as depicted in [Figure 8 1](#), [Figure 8 3](#) and [Tables 1](#) and [2](#). In case of a conflict, this report governs.
- 5.2 The Jordahl JTA (non-serrated) anchor channel systems are used to resist static, wind, and seismic (IBC Seismic Design Categories A and B) tension loads (N_{ua}) and shear loads perpendicular to the longitudinal channel axis ($V_{ua,y}$), or any combination of these loads applied at any location between the outermost anchors of the anchor channel in accordance with [Figure 2 1](#) of this report.

The Jordahl JXA, JXA-PC and JZA serrated (toothed) anchor channel systems, as well as Jordahl JTA (non-serrated) anchor channel systems in combination with notching bolts (JKB and JKC series), are used to resist static, wind, and seismic (IBC Seismic Design Categories A through F) tension loads (N_{ua}), shear loads perpendicular to the longitudinal channel axis ($V_{ua,y}$), and shear loads longitudinal with the channel axis or any combination of these loads applied at any location between the outermost anchors of the anchor channel in accordance with [Figure 2-1](#) of this report.

- 5.3 The Jordahl JTA, JXA, JXA-PC, and JZA anchor channel systems must be limited to the use in cracked or uncracked normal weight and sand-lightweight concrete having a specified compressive strength, f'_c , of 2,500 psi to 10,000 psi (17.2 MPa to 69.0 MPa) [minimum of 24 MPa is required under ADIBC Appendix L, Section 5.1.1].
- 5.4 The use of the Jordahl JTA, JXA, JXA-PC, and JZA anchor channel systems in all-lightweight concrete is beyond the scope of this report.
- 5.5 Strength design values must be established in accordance with Section 4.1 of this report.
- 5.6 Allowable stress design values are established in Section 4.2 of this report.
- 5.7 Minimum and maximum anchor spacing and minimum edge distance as well as minimum member thickness must comply with the values given in [Tables 1](#) and [2](#) of this report.
- 5.8 Channel bolt installation must include the use of a plate washer or fixture and proper tightening torque. Apply the installation torque T_{inst} to the channel bolt with a calibrated torque wrench. Do not exceed the value T_{inst} in the table in [Figure 8-3](#).
- 5.9 Prior to anchor channel system installation, calculations and details demonstrating compliance with this report must be submitted to the code official. The calculations and details must be prepared by a registered design professional where required by the statutes of the jurisdiction in which the project is to be constructed.
- 5.10 Where not otherwise prohibited in the code, Jordahl JTA, JXA, JXA-PC, and JZA anchor channel systems are permitted for use with fire-resistance-rated construction provided that at least one of the following conditions is fulfilled:
 - Anchor channel systems are used to resist wind or seismic forces only.
 - Anchor channel systems that support a fire-resistance-rated envelope or a fire-resistance-rated membrane are protected by approved fire-resistance-rated materials, or have been evaluated for resistance to fire exposure in accordance with recognized standards.
 - Anchor channel systems are used to support nonstructural elements.
- 5.11 Since an acceptance criteria for evaluating data to determine the performance of anchor channel systems subjected to fatigue or shock loading is unavailable at this time, the use of these anchor channel systems under such conditions is beyond the scope of this report.
- 5.12 Use of hot-dipped galvanized carbon steel anchor channel systems is permitted for exterior exposure or damp environments. In case anchor channels are cut after applying the zinc coating, only use in dry internal conditions is permitted.
- 5.13 Steel anchoring materials in contact with preservative-treated and fire-retardant-treated wood shall be of zinc-coated carbon steel. The minimum coating weights for zinc-coated steel shall comply with ASTM A153.
- 5.14 Special inspection must be provided in accordance with Section 4.4 of this report.
- 5.15 Jordahl JTA, JXA, JXA-PC, and JZA anchor channel systems are produced under an approved quality-control program with inspections performed by ICC-ES.

6.0 EVIDENCE SUBMITTED

- 6.1 Data in accordance with [ICC-ES Acceptance Criteria for Anchor Channels in Concrete Elements \(AC232\)](#), dated August 2021.
- 6.2 Quality-control documentation.

7.0 IDENTIFICATION

- 7.1 The anchor channels are identified by the manufacturer's name, anchor channel type and size and material type (e.g. JTA W 53/34-A4), as well as the production lot number. Additionally, the profile designation in accordance with [Tables 23](#) and [24](#) of this report is visible on the anchor head in the channel after installation of the anchor channel and placement of the concrete. The evaluation report number (ESR-2854) is also listed on the product packaging.
- 7.2 Channel bolts are identified by packaging labeled with the manufacturer's name, bolt type, bolt diameter and length, bolt grade, corrosion protection type (e.g. JB M16x50 8.8 H.D.G.), evaluation report number (ESR 2854) and batch number. The manufacturer, bolt type, and bolt grade type is embossed into the channel bolt head.
- 7.3 The report holder's contact information is as follows:

JORDAHL
23 DEVON ROAD
BRAMPTON, ONTARIO L6T 5B6
CANADA
www.jordahl.ca
www.jordahlusa.com

8.0 NOTATIONS

Equations are provided in units of inches and pounds. For convenience, SI (metric) units are provided in parentheses where appropriate. Unless otherwise noted, values in SI units shall be not used in equations without conversion to units of inches and pounds.

b_{ch}	width of channel, as shown in Figure 8-2 , inch (mm)
c_a	edge distance of anchor channel, measured from edge of concrete member to axis of the nearest anchor as shown in Figure 4-4 , in. (mm)
c_{a1}	edge distance of anchor channel in direction 1 as shown in Figure 4-4 , in. (mm)
c'_{a1}	net distance between edge of the concrete member and the anchor channel: $c'_{a1} = c_{a1} - b_{ch}/2$ in. (mm)
$c_{a1,red}$	reduced edge distance of the anchor channel, as referenced in Eq. (39)
c_{a2}	edge distance of anchor channel in direction 2 as shown in Figure 4-4 , in. (mm)
$c_{a,max}$	edge distance used for design in all directions, taken as maximum of c_{a1} and c_{a2} , see Fig. RD.5.2.10.6 in. (mm)
$c_{a,min}$	edge distance used for design in all directions, taken as minimum of c_{a1} and c_{a2} , see Fig. RD.5.2.10.6 in. (mm)
c_{ac}	edge distance required to develop full concrete capacity in absence of reinforcement to control splitting, in. (mm)
c_{cr}	edge distance required to develop full concrete capacity in absence of anchor reinforcement, in. (mm)
$c_{cr,N}$	critical edge distance for anchor channel for tension loading for concrete breakout, in. (mm)
$c_{cr,Nb}$	critical edge distance for anchor channel for tension loading, concrete blow out, in. (mm)
$c_{cr,V}$	critical edge distance for anchor channel for shear loading, concrete edge breakout, in. (mm)
c_{min}	tested minimum edge distance as shown in Fig. RD.5.2.10.6, in. (mm)
d_1	diameter of head of round anchor, in. (mm)
d_2	shaft diameter of round anchor, in. (mm)
d_f	diameter of hole in the fixture, in. (mm)

d_a	diameter of anchor reinforcement, in. (mm)
d_s	diameter of channel bolt, in. (mm)
e_1	distance between shear load and concrete surface, in. (mm)
e_s	distance between the axis of the shear load and the axis of the anchor reinforcement resisting the shear load, in. (mm)
f	distance between anchor head and surface of the concrete, in. (mm)
f'_c	specified concrete compressive strength, psi (MPa)
f_{uta}	specified ultimate tensile strength of anchor, psi (MPa)
f_{utc}	specified ultimate tensile strength of channel, psi (MPa)
f_{utb}	specified ultimate tensile strength of channel bolt, psi (MPa)
f_y	specified yield tensile strength of steel, psi (MPa)
f_{ya}	specified yield strength of anchor, psi (MPa)
f_{yc}	specified yield strength of channel, psi (MPa)
f_{yb}	specified yield strength of channel bolt, psi (MPa)
h	thickness of concrete member, as shown in Figure 8-2 , inch (mm)
h_{ch}	height of channel, as shown in Figure 8-2 , in. (mm)
$h_{cr,V}$	critical member thickness, in. (mm)
h_{ef}	effective embedment depth, as shown in Figure 8-2 , in. (mm)
$h_{ef,red}$	reduced effective embedment depth, as referenced in Eq. (9), in. (mm)
h_{nom}	nominal embedment depth, as shown in Figure 8-2 , in. (mm)
k	load distribution factor, as referenced in Eq. (1)
K_{cp}	pryout factor
ℓ_A	nominal embedment depth, minus channel height, in. (mm)
ℓ	lever arm of the shear force acting on the channel bolt, in. (mm)
ℓ_{dh}	development length in tension of deformed bar or deformed wire with a standard hook, measured from critical section to outside end of hook, in. (mm)
ℓ_i	influence length of an external load N_{ua} along an anchor channel, in. (mm)
n_{ch}	number of adjacent anchor channels
n_1	number of anchor rows in direction 1 perpendicular to the edge
s	spacing of anchors in direction of longitudinal axis of channel, in. (mm)
S_{chb}	center-to-center distance between channel bolts in direction of longitudinal axis of channel, in. (mm)
$S_{ch,x}$	center-to-center spacing of adjacent end anchors of anchor channels in linear configuration, in. (mm)
$S_{ch,y}$	axis-to-axis spacing of two anchor channels in parallel configuration, in. (mm)
S_{cr}	anchor spacing required to develop full concrete capacity in absence of anchor reinforcement, in. (mm)
$S_{cr,N}$	critical anchor spacing for tension loading, concrete breakout, in. (mm)
S_{max}	maximum allowable spacing of anchors connected to channels, in. (mm)
S_{min}	minimum allowable spacing of anchors connected to channels, in. (mm)
$S_{cr,Nb}$	critical anchor spacing for tension loading, concrete blow-out, in. (mm)
$S_{cr,V}$	critical anchor spacing for shear loading, concrete edge breakout, in. (mm)
t_h	thickness of head portion of headed anchor, in. (mm)
W_A	width of I-shaped or T-shaped anchor, as shown in Figure 8-2 , in. (mm)

x	distance between end of channel and nearest anchor, in. (mm)
z	internal lever arm of the concrete member, in. (mm)
A_{brg}	bearing area of anchor head, in. ² (mm ²)
A_i	ordinate at the position of the anchor i , as illustrated in Figure 4-1 , in. (mm)
$A_{se,N}$	effective cross-sectional area of anchor or channel bolt in tension, in. ² , (mm ²)
$A_{se,V}$	effective cross-sectional area of channel bolt in shear (mm ²)
I_y	moment of inertia of the channel about principal y -axis, in. ⁴ (mm ⁴)
M_1	bending moment on fixture around axis in direction 1, lb-in (Nm)
M_2	bending moment on fixture around axis in direction 2, lb-in (Nm)
$M_{s,flex}$	nominal flexural strength of the anchor channel, lb-in (Nm)
M_{ss}	flexural strength of the channel bolt, lb-in (Nm)
M_{ss}^0	nominal flexural strength of the channel bolt, lb-in (Nm)
$M_{s,flex, allowable, ASD}$	allowable bending moment due to tension loads for use in allowable stress design environments, lb-in (Nm)
$M_{u,flex}$	bending moment on the channel due to tension loads, lb-in (Nm)
N_b	basic concrete breakout strength of a single anchor in tension, lb (N)
N_{ca}	nominal strength of anchor reinforcement to take up tension loads, lb (N)
N_{cb}	concrete breakout strength of a single anchor of anchor channel in tension, lb (N)
N_n	lowest nominal tension strength from all appropriate failure modes under tension, lb (N)
N_p	pullout strength of a single anchor of an anchor channel in tension, lb (N)
N_{pn}	nominal pullout strength of a single anchor of an anchor channel in tension, lb (N)
N_{nc}	nominal tension strength of one anchor from all concrete failure modes (lowest value of N_{cb} [anchor channels without anchor reinforcement to take up tension loads] or N_{ca} [anchor channels with anchor reinforcement to take up tension loads], N_{pn} , and N_{sb})
N_{ns}	nominal steel strength of anchor channel loaded in tension (lowest value of N_{sa} , N_{sc} and N_{sl}), lb (N)
$N_{ns,a}$	nominal tension strength for steel failure of anchor or connection between anchor and channel (lowest value of N_{sa} and N_{sc})
N_{sa}	nominal tensile steel strength of a single anchor, lb (N)
N_{sb}	nominal concrete side-face blowout strength, lb (N)
N_{sb}^0	basic nominal concrete side-face blowout strength, lb (N)
N_{sc}	nominal tensile steel strength of the connection between channel and anchor, lb (N)
N_{sl}	nominal tensile steel strength of the local bending of the channel lips, lb (N)
N_{ss}	nominal tensile strength of a channel bolt, lb (N)
N_{ua}^a	factored tension load on a single anchor of the anchor channel, lb (N)
$N_{ua,i}^a$	factored tension load on anchor i of the anchor channel, lb (N)
N_{ua}^b	factored tension load on a channel bolt, lb (N)
$N_{ua,re}$	factored tension load acting on the anchor reinforcement, lb (N)
$T_{allowable, ASD}$	allowable tension load for use in allowable stress design environments, lb (N)
T_{inst}	installation torque moment given in installation instructions (MPII), lb-in. (N-m)
V_b	basic concrete breakout strength in shear of a single anchor, lb (N)
$V_{ca,x}$	nominal strength of the anchor reinforcement of one anchor to take up shear loads longitudinal with the channel axis, lb (N)

$V_{ca,y}$	nominal strength of the anchor reinforcement of one anchor to take up shear loads perpendicular to the channel axis, lb (N)
$V_{ca,y,max}$	maximum value of $V_{ca,y}$ of one anchor to be used in design, lb (N)
$V_{cb,x}$	nominal concrete breakout strength in shear longitudinal with the channel axis of an anchor channel, lb (N)
$V_{cb,y}$	nominal concrete breakout strength in shear perpendicular to the channel axis of an anchor channel, lb (N)
V_{cp}	nominal pry-out strength of a single anchor ($V_{cp,x} = V_{cp,y}$), lb (N)
$V_{cp,x}$	nominal pry-out strength longitudinal with the channel axis of a single anchor, lb (N)
$V_{cp,y}$	nominal pry-out strength perpendicular to the channel axis of a single anchor, lb (N)
$V_{n,x}$	lowest nominal steel strength from all appropriate failure modes under shear longitudinal with the channel axis, lb (N)
$V_{n,y}$	lowest nominal steel strength from all appropriate failure modes under shear perpendicular to the channel axis, lb (N)
V_{nc}	nominal shear strength of one anchor from all concrete failure modes (lowest value of V_{cb} [anchor channels with anchor reinforcement to take up shear loads] or V_{ca} [anchor channels with anchor reinforcement to take up shear loads] and V_{cp})
V_{ns}	Nominal steel strength of anchor channel loaded in shear (lowest value of V_{sa} , V_{sc} , and V_{sl})
$V_{ns,a}$	nominal shear strength for steel failure of anchor or connection between anchor and channel (lowest value of V_{sa} and V_{sc})
$V_{sa,x}$	nominal shear steel strength longitudinal with the channel axis of a single anchor, lb (N)
$V_{sa,y}$	nominal shear steel strength perpendicular to the channel axis of a single anchor, lb (N)
$V_{sa,x,seis}$	nominal seismic shear steel strength longitudinal with the channel axis of a single anchor, lb (N)
$V_{sa,y,seis}$	nominal seismic shear steel strength perpendicular to the channel axis of a single anchor, lb (N)
$V_{sc,x}$	nominal shear strength longitudinal with the channel axis of connection between one anchor and the anchor channel, lb (N)
$V_{sc,y}$	nominal shear strength perpendicular to the channel axis of connection between one anchor and the anchor channel, lb (N)
$V_{sc,x,seis}$	nominal seismic shear strength longitudinal with the channel axis of connection between one anchor bolt and the anchor channel, lb (N)
$V_{sc,y,seis}$	nominal seismic shear strength perpendicular to the channel axis of connection between one anchor bolt and the anchor channel, lb (N)
$V_{sl,x}$	nominal shear steel strength longitudinal with the channel axis of the local bending of the channel lips, lb (N)
$V_{sl,y}$	nominal shear steel strength perpendicular to the channel axis of the local bending of the channel lips, lb (N)
$V_{sl,x,seis}$	nominal seismic shear steel strength longitudinal with the channel axis of the local bending of the channel lips, lb (N)
$V_{sl,y,seis}$	nominal seismic shear steel strength perpendicular to the channel axis of the local bending of the channel lips, lb (N)
V_{ss}	nominal strength of channel bolt in shear, lb (N)
$V_{ss,M}$	nominal strength of channel bolt in case of shear with lever arm, lb (N)
V_{ua}	factored shear load on anchor channel, lb (N)
$V_{ua,x}$	factored shear load on anchor channel longitudinal with the channel axis, lb (N)
$V_{ua,y}$	factored shear load on anchor channel perpendicular to the channel axis, lb (N)
V_{ua}^a	factored shear load on a single anchor of the anchor channel, lb (N)
$V_{ua,x}^a$	factored shear load on a single anchor of the anchor channel longitudinal with the channel axis, lb (N)
$V_{ua,y}^a$	factored shear load on a single anchor of the anchor channel perpendicular to the channel axis, lb (N)

$V_{ua,i}^a$	factored shear load on anchor i of the anchor channel, lb (N)
$V_{ua,x,i}^a$	factored shear load on anchor i of the anchor channel in longitudinal channel axis, lb (N)
$V_{ua,y,i}^a$	factored shear load on anchor i of the anchor channel perpendicular to the channel axis, lb (N)
V_{ua}^b	factored shear load on a channel bolt, lb (N)
$V_{ua,x}^b$	factored shear load on a channel bolt in longitudinal channel axis, lb (N)
$V_{ua,y}^b$	factored shear load on a channel bolt perpendicular to the channel axis, lb (N)
$V_{x,allowable,ASD}$	allowable shear load in longitudinal channel axis for use in allowable stress design environments, lb (N)
$V_{y,allowable,ASD}$	allowable shear load perpendicular to the channel axis for use in allowable stress design environments, lb (N)
α	exponent of interaction equation (see Section 4.1.3.6)
α_{ASD}	conversion factor for allowable stress design (see Section 4.2)
$\alpha_{ch,N}$	factor to account for the influence of channel size on concrete breakout strength in tension
α_M	factor to account for the influence of restraint of fixture on the flexural strength of the channel bolt
$\alpha_{ch,V}$	factor to account for the influence of channel size and anchor diameter on concrete edge breakout strength in shear ($(lb^{0.5}/in)^{0.33}$ ($N^{0.5}/mm^{0.33}$))
β_1	exponent in Eq. (37) to account for the influence of the member depth on the concrete edge breakout strength in accordance with Tables 13 and 14
λ	Modification factor for sand-lightweight concrete
$\psi_{c,N}$	modification factor to account for influence of cracked or uncracked concrete on concrete breakout strength
$\psi_{c,Nb}$	modification factor to account for influence of cracked or uncracked concrete on concrete blowout strength
$\psi_{c,V}$	modification factor to account for influence of cracked or uncracked concrete for concrete edge breakout strength
$\psi_{co,N}$	modification factor for corner effects on concrete breakout strength for anchors loaded in tension
$\psi_{co,Nb}$	modification factor for corner effects on concrete blowout strength for anchors loaded in tension
$\psi_{co,V}$	modification factor for corner effects on concrete edge breakout strength for anchor channels loaded in shear
$\psi_{cp,N}$	modification factor for anchor channels to control splitting
$\psi_{ed,N}$	modification factor for edge effect on concrete breakout strength for anchors loaded in tension
$\psi_{g,Nb}$	modification factor to account for influence of bearing area of neighboring anchors on concrete blowout strength for anchors loaded in tension
$\psi_{h,Nb}$	modification factor to account for influence of member thickness on concrete blowout strength for anchors loaded in tension
$\psi_{h,V}$	modification factor to account for influence of member thickness on concrete edge breakout strength for anchors channels loaded in shear
$\psi_{s,N}$	modification factor to account for influence of location and loading of neighboring anchors on concrete breakout strength for anchor channels loaded in tension
$\psi_{s,Nb}$	modification factor to account for influence of location and loading of neighboring anchors on concrete blowout strength for anchor channels loaded in tension
$\psi_{s,V}$	modification factor to account for influence of location and loading of neighboring anchors on concrete edge breakout strength for anchor channels loaded in shear

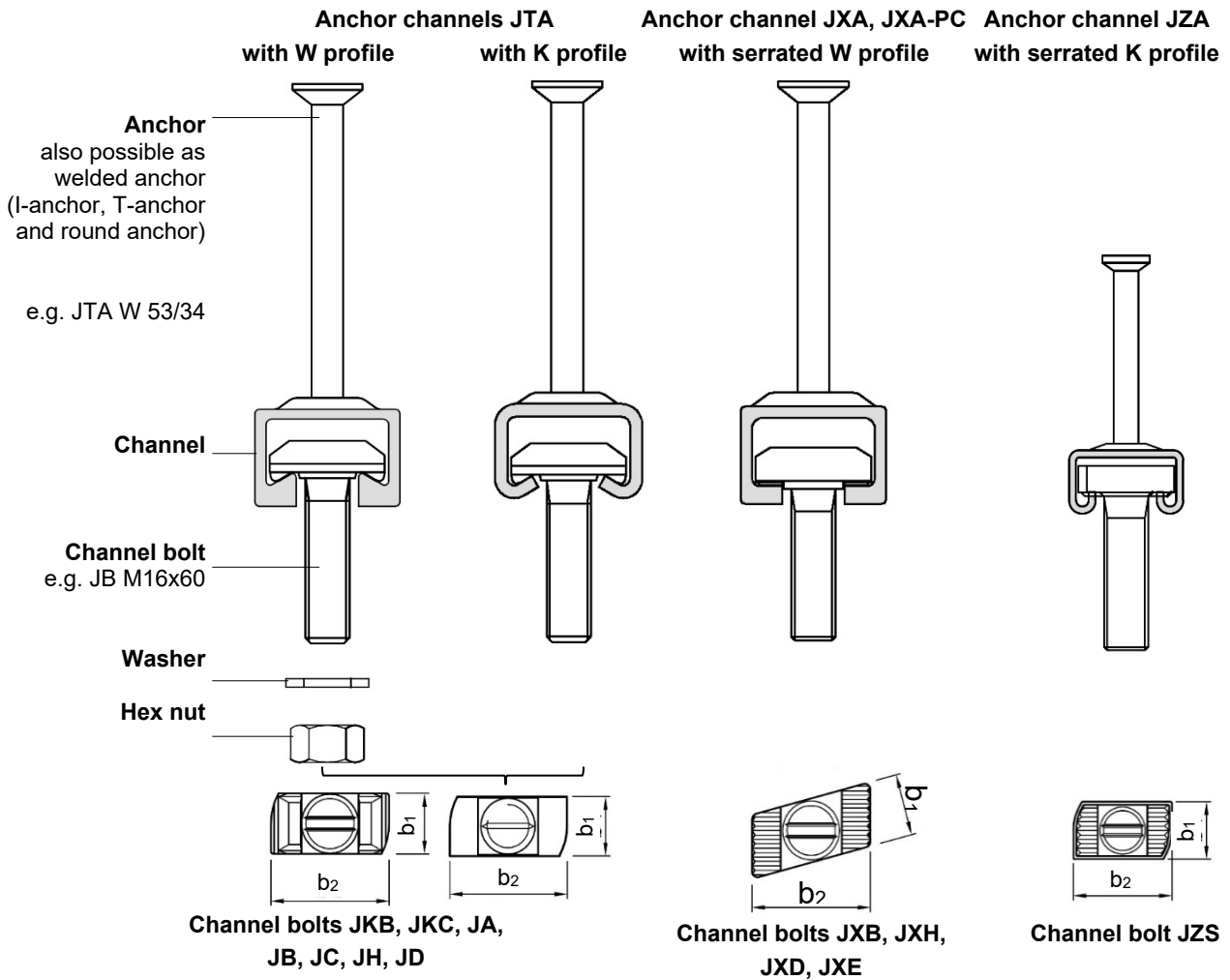

FIGURE 8-1—INSTALLATION PARAMETERS

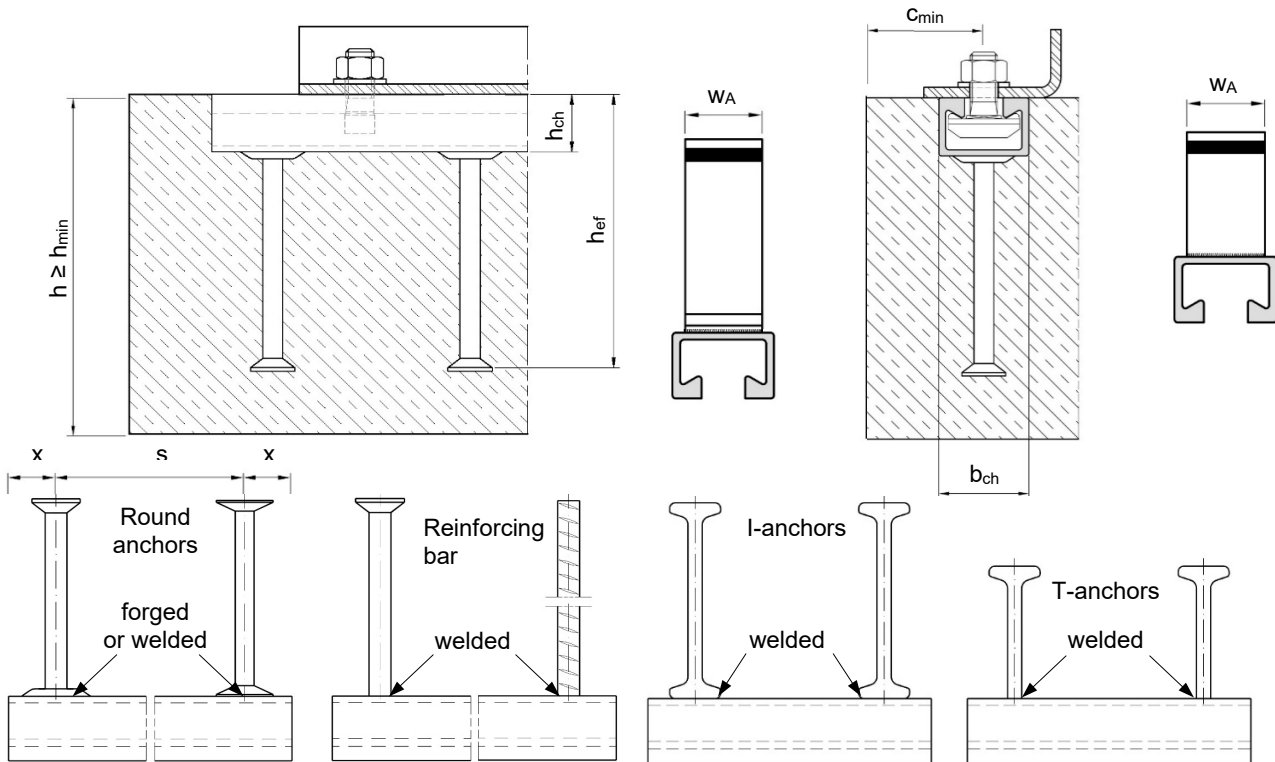

FIGURE 8-2—ANCHOR (CONNECTION) TYPES

TABLE 1—INSTALLATION PARAMETERS FOR JORDAHL JTA ANCHOR CHANNELS

Parameter	Symbol	Units	JTA								
			K28/15	K38/17	W40/22	W40+	W50/30	W50+	W53/34	W55/42 ¹	W72/48 ¹
Channel height	h_{ch}	in (mm)	0.60 (15.25)	0.69 (17.50)	0.91 (23.00)	0.91 (23.00)	1.18 (30.00)	1.18 (30.00)	1.32 (33.50)	1.65 (42.00)	1.91 (48.50)
Channel width	b_{ch}	in (mm)	1.10 (28.00)	1.50 (38.00)	1.56 (39.50)	1.56 (39.50)	1.93 (49.00)	1.93 (49.00)	2.07 (52.5.0)	2.15 (54.5.0)	2.83 (72.00)
Moment of inertia	I_y	in ⁴ (mm ⁴)	0.010 (4060)	0.021 (8547)	0.048 (20029)	0.048 (20029)	0.127 (52896)	0.127 (52896)	0.224 (93262)	0.450 (187464)	0.840 (349721)
Minimum anchor spacing	s_{min}	in (mm)	1.97 (50)	1.97 (50)	1.97 (50)	1.97 (50)	1.97 (50)	1.97 (50)	3.15 (80)	3.15 (80)	3.15 (80)
Maximum anchor spacing	s_{max}	in (mm)	7.87 (200)	7.87 (200)	9.84 (250)	9.84 (250)	9.84 (250)	9.84 (250)	9.84 (250)	11.81 (300)	15.75 (400)
Min. Effective embedment depth, round anchors or I-anchors	$h_{ef,min}$	in (mm)	1.77 (45)	2.99 (76)	3.11 (79)	3.58 (91)	3.70 (94)	4.17 (106)	6.10 (155)	6.89 (175)	7.05 (179)
Min. effective embedment depth, T-anchors	$h_{ef,min}$	in (mm)	- -	- -	2.24 (57)	3.58 (91)	2.80 (71)	4.17 (106)	2.99 (76)	3.31 (84)	- -
Thickness of the anchor head for round anchors	t_h	in (mm)	0.08 (2.0)	0.12 (3.0)	0.08 (2.0)	0.08 (2.0)	0.12 (3.0)	0.12 (3.0)	0.12 (3.0)	0.14 (3.5)	0.14 (3.5)
Thickness of the anchor head for I- or T-anchors	t_h	in (mm)	- -	- -	0.13 (3.3)	0.20 (5.0)	0.14 (3.5)	0.20 (5.0)	0.20 (5.0)	0.24 (6.0)	- -
Nominal embedment depth	h_{nom}	in (mm)	$h_{nom} = h_{ef} + t_h$								
Reinforcing bar size	d_b	-	-	-	#3	-	#4	-	#5	#6	-
Length of reinforcing bar	ℓ_R	-	According to ACI 318-08 or ACI 318-11 Section 12.14 or ACI 318-14 or ACI 318-19 Section 25.5								
Minimum edge distance, round anchors and I-anchors, normal- and lightweight concrete	c_{min}	in (mm)	1.60 (41)	2.00 (51)	2.00 (51)	2.00 (51)	2.00 (51)	2.00 (51)	4.00 (102)	4.00 (102)	6.00 (152)
Minimum edge distance, T-anchors, normal-weight concrete	c_{min}	in (mm)	- -	- -	2.00 (51)	2.00 (51)	2.00 (51)	2.00 (51)	3.00 (76)	3.00 (76)	- -
Minimum edge distance, T-anchors, lightweight concrete	c_{min}	in (mm)	- -	- -	2.00 (51)	2.00 (51)	2.00 (51)	2.00 (51)	3.00 (76)	- -	- -
Minimum end spacing	x_{min}	in (mm)	0.98 (25)	0.98 (25)	0.98 (25)	0.98 (25)	0.98 (25)	0.98 (25)	1.38 (35)	1.38 (35)	1.38 (35)
Anchor shaft diameter	d_2	in (mm)	0.28 (7.0)	0.35 (9.0)	0.33 (8.5)	0.33 (8.5)	0.35 (9.0)	0.39 (10.0)	0.45 (11.5)	0.61 (15.5)	0.61 (15.5)
Head diameter for round anchors	d_1	in (mm)	0.47 (12.0)	0.67 (17.0)	0.59 (15.0)	0.59 (15.0)	0.69 (17.5)	0.77 (19.5)	0.93 (23.5)	1.10 (28.0)	1.22 (31.0)
Minimum width of I- or T-anchors	w_A	in (mm)	- -	- -	0.79 (20)	0.98 (25)	0.98 (25)	1.18 (30)	1.57 (40)	1.77 (45)	- -
Minimum concrete member thickness, round anchors and I-anchors	h_{min}	in (mm)	2.60 (66)	3.78 (96)	4.17 (106)	4.49 (114)	4.57 (116)	5.08 (129)	7.13 (181)	8.11 (206)	8.31 (211)
Minimum concrete member thickness, T-anchors	h_{min}	in (mm)	- -	- -	3.74 (95)	4.49 (114)	3.94 (100)	5.08 (129)	4.33 (110)	5.12 (130)	- -

¹ Anchor channels available only in carbon steel.

TABLE 2—INSTALLATION PARAMETERS FOR JORDAHL JZA, JXA AND JXA-PC ANCHOR CHANNELS

Parameter	Symbol	Units	JZA		JXA			JXA-PC
			K41/22	W29/20	W38/23 ¹	W53/34 ¹	W64/44 ¹	W53/34
Channel height	h_{ch}	in (mm)	0.87 (22.00)	0.79 (20.00)	0.91 (23.00)	1.34 (34.00)	1.73 (44.00)	1.34 (34.00)
Channel width	b_{ch}	in (mm)	1.61 (41.00)	1.14 (29.00)	1.50 (38.00)	2.07 (52.50)	2.52 (64.00)	2.07 (52.50)
Moment of inertia	I_y	in ⁴ (mm ⁴)	0.0360 (15000)	0.0245 (10200)	0.051 (21100)	0.224 (93260)	0.581 (241800)	0.224 (93260)
Minimum anchor spacing	s_{min}	in (mm)	1.97 (50)	1.97 (50)	1.97 (50)	3.15 (80)	3.15 (80)	3.15 (80)
Maximum anchor spacing	s_{max}	in (mm)	9.84 (250)	7.87 (200)	9.84 (250)	9.84 (250)	9.84 (250)	9.84 (250)
Min. Effective embedment depth, round anchors	$h_{ef,min}$	in (mm)	2.95 (75)	3.07 (78)	3.74 (95)	6.10 (155)	-	7.09 (180)
Min. effective embedment depth, I-anchors or T-anchors	$h_{ef,min}$	in (mm)	-	-	2.13 (54)	2.99 (76)	7.05 (179)	-
Thickness of the anchor head for round anchors	t_h	in (mm)	0.12 (3.0)	0.12 (3.0)	0.12 (3.0)	0.12 (3.0)	-	0.16 (4.0)
Thickness of the anchor head for I- or T-anchors	t_h	in (mm)	-	-	0.20 ¹ (5.0)	0.20 ¹ (5.0)	0.20 ¹ (5.0)	-
Nominal embedment depth	h_{nom}	in (mm)	$h_{nom} = h_{ef} + t_h$					
Reinforcing bar size	d_b	-	-	-	#4	#5	-	-
Length of reinforcing bar	l_R	-	According to ACI 318-08 or ACI 318-11 Section 12.14 or ACI 318-14 or ACI 318-19 Section 25.5					
Minimum edge distance, round anchors and I-anchors, normal- and lightweight concrete	c_{min}	in (mm)	2.00 (51)	2.00 (51)	3.00 (76)	4.00 (102)	-	4.00 (102)
Minimum edge distance, T-anchors, normal-weight concrete	c_{min}	in (mm)	-	-	2.00 (51)	3.00 (76)	4.00 (102)	-
Minimum edge distance, T-anchors, lightweight concrete	c_{min}	in (mm)	-	-	-	-	4.00 (102)	-
Minimum end spacing	x_{min}	in (mm)	0.98 (25)	0.98 (25)	0.98 (25)	1.38 (35)	1.38 (35)	1.38 (35)
Anchor shaft diameter	d_2	in (mm)	0.35 (9.0)	0.35 (9.0)	0.39 (10.0)	0.45 (11.5)	-	0.55 (14.0)
Head diameter for round anchors	d_1	in (mm)	0.67 (17.0)	0.67 (17.0)	0.77 (19.5)	0.93 (23.5)	-	1.65 (42.0)
Minimum width of I- or T-anchors	w_A	in (mm)	-	-	0.79 (20)	1.38 (35)	1.77 (45)	-
Minimum concrete member thickness, round anchors and I-anchors	h_{min}	in (mm)	4.72 (120)	4.72 (120)	4.72 (120)	7.48 (190)	-	7.48 (190)
Minimum concrete member thickness, T-anchors	h_{min}	in (mm)	-	-	3.94 (100)	4.33 (110)	8.27 (210)	-

¹ Channels with I- and T-anchors available only in carbon steel.

TABLE 3—JORDAHL JTA ANCHOR CHANNELS AND CORRESPONDING CHANNEL BOLT COMBINATIONS

Parameter	Symbol	Units	JTA									
			K28/15	K38/17	W40/22 W40+		W50/30 W50+		W53/34		W55/42	W72/48
Bolt Type	-	-	JD ¹	JH ¹	JC ²	JKC ²	JB ²	JKB ²	JB ²	JKB ²	JB ²	JA ²
Diameter	d _s	(mm)	6	-	-	-	-	-	-	-	-	-
			8	-	-	-	-	-	-	-	-	-
			10	10	10	-	10	-	10	-	10	-
			12	12	12	12 ³	12	-	12	-	12	-
			-	16	16	16 ³	16	16 ³	16	16 ³	16	-
			-	-	-	-	20	20 ³	20	20 ³	20	20
			-	-	-	-	-	-	-	-	24	24
			-	-	-	-	-	-	-	-	-	27
-	-	-	-	-	-	-	-	-	-	30		

¹Hammer-head channel bolts.

²Hooked-head channel bolts.

³ For notching bolts JKB and JKC steel-steel contact as described in [Figure 8-3](#), point 4B must be provided.

TABLE 4—JORDAHL JZA, JXA AND JXA-PC ANCHOR CHANNELS AND CORRESPONDING CHANNEL BOLT COMBINATIONS

Parameter	Symbol	Units	JZA	JXA				JXA-PC
			K41/22	W29/20	W38/23	W53/34	W64/44	W53/34
Bolt Type	-	-	JZS ¹	JXD ¹	JXH ¹	JXB ¹	JXE ¹	JXB ¹
Diameter	d _s	(mm)	-	10	-	-	-	-
			12	12	12	-	-	-
			16	-	16	16	-	16
			-	-	-	20	20	20
			-	-	-	-	24	-

¹Toothed channel bolts

TABLE 5—STEEL TENSION STRENGTH DESIGN INFORMATION, JORDAHL JTA ANCHOR CHANNELS³

Parameter	Symbol	Units	JTA								
			K28/15	K38/17	W40/22	W40+	W50/30	W50+	W53/34	W55/42 ²	W72/48 ²
Nominal tensile steel strength for local failure of channel lips	N_{sl}	lb (kN)	2025 (9.0)	4045 (18.0)	6745 (30.0)	6745 (30.0)	8095 (36.0)	8095 (36.0)	14615 (65.0)	26750 (119.0)	24730 (110.0)
Nominal tensile steel strength for local failure of channel lips with notching bolts for seismic design	$N_{sl,seis}$	lb (kN)	- -	- -	6745 (30.0)	6745 (30.0)	8095 (36.0)	8095 (36.0)	8095 (36.0)	- -	- -
Strength reduction factor for local failure of channel lips ¹	ϕ	-	0.75 (0.80)								
Nominal tensile steel strength of a single anchor	N_{sa}	lb (kN)	2025 (9.0)	4045 (18.0)	4495 (20.0)	6745 (30.0)	6970 (31.0)	8765 (39.0)	12365 (55.0)	22930 (102.0)	22480 (100.0)
Nominal tensile steel strength of a single anchor with notching bolts for seismic design	$N_{sa,seis}$	lb (kN)	- -	- -	4495 (20.0)	4495 (20.0)	6970 (31.0)	6970 (31.0)	6970 (31.0)	- -	- -
Nominal tensile steel strength of a single anchor (reinforcing bar)	N_{sa}	lb (kN)	- -	- -	8770 (39.0)	-	15960 (71.0)	-	24730 (110.0)	35095 (156.1)	-
Nominal tensile steel strength of a single anchor (reinforcing bar) with notching bolts for seismic design	$N_{sa,seis}$	lb (kN)	- -	- -	4495 (20.0)	-	6970 (31.0)	-	6970 (31.0)	-	-
Strength reduction factor for anchor failure ¹	ϕ	-	0.75 (0.80)								
Nominal tensile steel strength of connection between anchor and channel	N_{sc}	lb (kN)	2025 (9.0)	4045 (18.0)	4495 (20.0)	6745 (30.0)	6970 (31.0)	8320 (37.0)	12365 (55.0)	22930 (102.0)	22480 (100.0)
Nominal tensile steel strength of connection between anchor and channel with notching bolts for seismic design	$N_{sc,seis}$	lb (kN)	- -	- -	4495 (20.0)	4495 (20.0)	6970 (31.0)	6970 (31.0)	6970 (31.0)	- -	- -
Nominal tensile steel strength of connection between anchor (reinforcing bar) and channel	N_{sc}	lb (kN)	- -	- -	6050 (26.9)	-	8140 (36.2)	-	13985 (62.2)	19265 (85.7)	-
Nominal tensile steel strength of connection between anchor (reinforcing bar) and channel with notching bolts for seismic design	$N_{sc,seis}$	lb (kN)	- -	- -	4495 (20.0)	-	6970 (31.0)	-	6970 (31.0)	-	-
Strength reduction factor for failure of connection between anchor and channel ¹	ϕ	-	0.75 (0.80)								
Nominal bending strength of the anchor channel, carbon steel	$M_{s,flex}$	lb-in (Nm)	2805 (317)	5135 (580)	10770 (1217)	10770 (1217)	17860 (2018)	17860 (2018)	28460 (3215)	59130 (6681)	80540 (9100)
Nominal bending strength of the anchor channel, stainless steel	$M_{s,flex}$	lb-in (Nm)	2865 (324)	5245 (593)	12155 (1373)	12155 (1373)	20095 (2270)	20095 (2270)	32015 (3617)	-	-
Nominal bending strength of the anchor channel with notching bolts, carbon steel	$M_{s,flex}$	lb-in (Nm)	- -	- -	10065 (1137)	10065 (1137)	15540 (1756)	15540 (1756)	30870 (3488)	-	-
Nominal bending strength of the anchor channel with notching bolts, stainless steel	$M_{s,flex}$	lb-in (Nm)	- -	- -	11320 (1279)	11320 (1279)	17480 (1975)	17480 (1975)	34730 (3924)	-	-
Nominal bending strength of the anchor channel with notching bolts for seismic design, carbon steel	$M_{s,flex,seis}$	lb-in (Nm)	- -	- -	10065 (1137)	10065 (1137)	15540 (1756)	15540 (1756)	15540 (1756)	-	-
Nominal bending strength of the anchor channel with notching bolts for seismic design, stainless steel	$M_{s,flex,seis}$	lb-in (Nm)	- -	- -	11320 (1279)	11320 (1279)	17480 (1975)	17480 (1975)	17480 (1975)	-	-
Strength reduction factor for bending failure ¹	ϕ	-	0.85 (0.90)								

¹The tabulated value of ϕ applies when the load combinations of Section 1605.1 of the 2021 IBC or Section 1605.2 of the 2018, 2015, or 2012 IBC, ACI 318 (-19 or -14) Section 5.3 or ACI 318-11 Section 9.2 are used. If the load combinations of ACI 318-11 Appendix C are used, the appropriate value of ϕ in parentheses must be used.

²Anchor channels available only in carbon steel.

³Values valid for carbon steel and stainless steel, unless noted otherwise.

TABLE 6—STEEL TENSION STRENGTH DESIGN INFORMATION, JORDAHL JZA AND JXA ANCHOR CHANNELS

Parameter	Symbol	Units	JZA	JXA ²				JXA-PC
			K41/22 ²	W29/20 ²	W38/23	W53/34	W64/44 ³	W53/34
Nominal tensile steel strength for local failure of channel lips, carbon steel	N_{sl}	lb (kN)	3490 (15.5)	4475 (19.9)	8330 (37.0)	17685 (78.7)	24685 (109.8)	19660 (87.4)
Nominal tensile steel strength for local failure of channel lips for seismic design, carbon steel	$N_{sl,seis}$	lb (kN)	3490 (15.5)	3370 (15.0)	8330 (37.0)	17685 (78.7)	24685 (109.8)	19660 (87.4)
Nominal tensile steel strength for local failure of channel lips, stainless steel	N_{sl}	lb (kN)	4050 (18.0)	-	8790 (39.1)	14520 (64.6)	-	-
Nominal tensile steel strength for local failure of channel lips for seismic design, stainless steel	$N_{sl,seis}$	lb (kN)	4050 (18.0)	-	8790 (39.1)	14520 (64.6)	-	-
Strength reduction factor for local failure of channel lips ¹	ϕ^1	-	0.75 (0.80)					
Nominal tensile steel strength of a single anchor, carbon steel	N_{sa}	lb (kN)	5720 (25.4)	5720 (25.4)	7065 (31.5)	12845 (57.1)	25860 (115.0)	19035 (84.7)
Nominal tensile steel strength of a single anchor for seismic design, carbon steel	$N_{sa,seis}$	lb (kN)	5720 (25.4)	4450 (19.8)	7065 (31.5)	12845 (57.1)	25860 (115.0)	19035 (84.7)
Nominal tensile steel strength of a single anchor, stainless steel	N_{sa}	lb (kN)	5720 (25.4)	-	7065 (31.5)	12845 (57.1)	-	-
Nominal tensile steel strength of a single anchor for seismic design, stainless steel	$N_{sa,seis}$	lb (kN)	5720 (25.4)	-	7065 (31.5)	12845 (57.1)	-	-
Nominal tensile steel strength of a single anchor (reinforcing bar), carbon steel	N_{sa}	lb (kN)	-	-	15960 (71.0)	24730 (110.0)	-	-
Nominal tensile steel strength of a single anchor (reinforcing bar) for seismic design, carbon steel	$N_{sa,seis}$	lb (kN)	-	-	7080 (31.5)	12835 (57.1)	-	-
Strength reduction factor for anchor failure ¹	ϕ^1	-	0.75 (0.80)					
Nominal tensile steel strength of connection between anchor and channel, carbon steel	N_{sc}	lb (kN)	3270 (14.5)	4340 (19.3)	7510 (33.4)	16255 (72.3)	23920 (106.4)	19660 (87.4)
Nominal tensile steel strength of connection between anchor and channel for seismic design, carbon steel	$N_{sc,seis}$	lb (kN)	3270 (14.5)	3370 (15.0)	7510 (33.4)	16255 (72.3)	23920 (106.4)	19660 (87.4)
Nominal tensile steel strength of connection between anchor and channel, stainless steel	N_{sc}	lb (kN)	4050 (18.0)	-	8790 (39.1)	11020 (49.0)	-	-
Nominal tensile steel strength of connection between anchor and channel for seismic design, stainless steel	$N_{sc,seis}$	lb (kN)	4050 (18.0)	-	8790 (39.1)	11020 (49.0)	-	-
Nominal tensile steel strength of connection between anchor and channel (reinforcing bar), carbon steel	N_{sc}	lb (kN)	-	-	7690 (34.2)	15310 (68.1)	-	-
Nominal tensile steel strength of connection between anchor (reinforcing bar) and channel for seismic design, carbon steel	$N_{sc,seis}$	lb (kN)	-	-	7510 (33.4)	15310 (68.1)	-	-
Strength reduction factor for failure of connection between anchor and channel ¹	ϕ^1	-	0.75 (0.80)					
Nominal bending strength of the anchor channel, carbon steel	$M_{s,flex}$	lb-in (Nm)	5600 (638)	5500 (620)	14140 (1597)	36745 (4152)	62875 (7104)	40235 (4545)
Nominal bending strength of the anchor channel for seismic design, carbon steel	$M_{s,flex,seis}$	lb-in (Nm)	5600 (638)	4285 (484)	14140 (1597)	36745 (4152)	62875 (7104)	40235 (4545)
Nominal bending strength of the anchor channel, stainless steel	$M_{s,flex}$	lb-in (Nm)	6800 (769)	-	10170 (1149)	28735 (3247)	-	-
Nominal bending strength of the anchor channel for seismic design, stainless steel	$M_{s,flex,seis}$	lb-in (Nm)	6800 (769)	-	10170 (1149)	28735 (3247)	-	-
Strength reduction factor for bending failure ¹	ϕ^1	-	0.85 (0.90)					

¹The tabulated value of ϕ applies when the load combinations of Section 1605.1 of the 2021 IBC or Section 1605.2 of the 2018, 2015, or 2012 IBC, ACI 318 (-19 or -14) Section 5.3 or ACI 318-11 Section 9.2 are used. If the load combinations of ACI 318-11 Appendix C are used, the appropriate value of ϕ in parentheses must be used.

²Available only with round anchors.

³ Available only with I-anchors.

TABLE 7—CONCRETE TENSION STRENGTH DESIGN INFORMATION, JORDAHL JTA AND JXA ANCHOR CHANNELS

Parameter	Symbol	Units	JTA								
			K28/15	K38/17	W40/22	W40+	W50/30	W50+	W53/34	W55/42	W72/48
Edge distance required to develop full concrete capacity in absence of anchor reinforcement	C_{ac}	in (mm)	$C_{ac} = 3 \cdot h_{ef}$								
Net bearing area of the anchor head, round anchors	A_{brg}	in ² (mm ²)	0.12 (74.6)	0.25 (163.4)	0.19 (120.0)	0.19 (120.0)	0.27 (176.9)	0.34 (220.1)	0.51 (329.9)	0.66 (427.1)	0.88 (566.1)
Net bearing area of the anchor head, I- or T-anchors	A_{brg}	in ² (mm ²)	- -	- -	0.40 (260.0)	0.43 (275.0)	0.50 (325.0)	0.51 (330.0)	0.68 (440.0)	0.90 (581.0)	- -
Strength reduction factor for tension, concrete failure modes ¹	ϕ	-	0.70 (0.75)								

¹ The tabulated value of ϕ applies when both the load combinations of Section 1605.1 of the 2021 IBC or Section 1605.2 of the 2018, 2015, or 2012 IBC, ACI 318 (-19 or -14) Section 5.3 or ACI 318-11 Section 9.2 are used and the requirements of ACI 318-19 17.5.3, ACI 318-14 17.3.3(c) or ACI 318-11 D.4.3(c), as applicable, for Condition B are met. Condition B applies where supplementary reinforcement is not provided. For installations where complying supplementary reinforcement can be verified, the ϕ factors described in ACI 318-19 17.5.3, ACI 318-14 17.3.3(c) or ACI 318-11 D.4.3(c), as applicable, for Condition A are allowed. If the load combinations of ACI 318-11 Appendix C are used, the appropriate value of ϕ must be determined in accordance with ACI 318-11 D.4.4(c).

TABLE 8—CONCRETE TENSION STRENGTH DESIGN INFORMATION, JORDAHL JZA AND JXA ANCHOR CHANNELS

Parameter	Symbol	Units	JZA	JXA				JXA-PC
			K41/22	W29/20	W38/23	W53/34	W64/44	W53/34
Edge distance required to develop full concrete capacity in absence of anchor reinforcement	C_{ac}	in (mm)	$C_{ac} = 3 \cdot h_{ef}$					
Net bearing area of the anchor head, round anchors	A_{brg}	in ² (mm ²)	0.25 (163.0)	0.25 (163.0)	0.34 (220.0)	0.51 (329.9)	- -	1.90 (1231.5)
Net bearing area of the anchor head, I- or T- anchors	A_{brg}	in ² (mm ²)	- -	- -	0.34 (220.0)	0.60 (385.0)	0.90 (581.0)	- -
Strength reduction factor for tension, concrete failure modes ¹	ϕ	-	0.70 (0.75)					

¹ The tabulated value of ϕ applies when both the load combinations of Section 1605.1 of the 2021 IBC or Section 1605.2 of the 2018, 2015, or 2012 IBC, ACI 318 (-19 or -14) Section 5.3 or ACI 318-11 Section 9.2 are used and the requirements of ACI 318-19 17.5.3, ACI 318-14 17.3.3(c) or ACI 318-11 D.4.3(c), as applicable, for Condition B are met. Condition B applies where supplementary reinforcement is not provided. For installations where complying supplementary reinforcement can be verified, the ϕ factors described in ACI 318-19 17.5.3, ACI 318-14 17.3.3(c) or ACI 318-11 D.4.3(c), as applicable, for Condition A are allowed. If the load combinations of ACI 318-11 Appendix C are used, the appropriate value of ϕ must be determined in accordance with ACI 318-11 D.4.4(c).

TABLE 9—STEEL PERPENDICULAR SHEAR STRENGTH DESIGN INFORMATION, JORDAHL JTA ANCHOR CHANNELS

Parameter	Symbol	Units	JTA						
			K28/15	K38/17	W40/22 W40+	W50/30 W50+	W53/34	W55/42 ²	W72/48 ²
Nominal shear steel strength for local failure of channel lips, normal-weight concrete	$V_{sl,y}$	lb (kN)	2025 (9.0)	4045 (18.0)	8545 (38.0)	13040 (58.0)	19335 (86.0)	27425 (122.0)	26975 (120.0)
Nominal shear steel strength for local failure of channel lips, sand lightweight concrete	$V_{sl,y}$	lb (kN)	- -	- -	8095 (36.0)	10790 (48.0)	18660 (83.0)	24505 (109.0)	26975 (120.0)
Nominal shear steel strength for local failure of channel lips for seismic design, normal-weight concrete	$V_{sl,y,seis}$	lb (kN)	- -	- -	8545 (38.0)	13040 (58.0)	13040 (58.0)	- -	- -
Nominal shear steel strength for local failure of channel lips for seismic design, sand lightweight concrete	$V_{sl,y,seis}$	lb (kN)	- -	- -	8095 (36.0)	10790 (48.0)	10790 (48.0)	- -	- -
Strength reduction factor for local failure of channel lips ¹	ϕ	-	0.75 (0.80)						
Nominal shear steel strength of a single anchor, normal-weight concrete	$V_{sa,y}$	lb (kN)	2025 (9.0)	4045 (18.0)	8545 (38.0)	13040 (58.0)	19335 (86.0)	27425 (122.0)	26975 (120.0)
Nominal shear steel strength of a single anchor, sand lightweight concrete	$V_{sa,y}$	lb (kN)	- -	- -	8095 (36.0)	10790 (48.0)	18660 (83.0)	24505 (109.0)	26975 (120.0)
Nominal shear steel strength of a single anchor for seismic design, normal-weight concrete	$V_{sa,y,seis}$	lb (kN)	- -	- -	8545 (38.0)	13040 (58.0)	13040 (58.0)	- -	- -
Nominal shear steel strength of a single anchor for seismic design, sand lightweight concrete	$V_{sa,y,seis}$	lb (kN)	- -	- -	8095 (36.0)	10790 (48.0)	10790 (48.0)	- -	- -
Strength reduction factor for anchor failure ¹	ϕ	-	0.75 (0.80)						
Nominal shear steel strength of connection between anchor and channel, normal-weight concrete	$V_{sc,y}$	lb (kN)	2025 (9.0)	4045 (18.0)	8545 (38.0)	13040 (58.0)	19335 (86.0)	27425 (122.0)	26975 (120.0)
Nominal shear steel strength of connection between anchor and channel, sand lightweight concrete	$V_{sc,y}$	lb (kN)	- -	- -	8095 (36.0)	10790 (48.0)	18660 (83.0)	24505 (109.0)	26975 (120.0)
Nominal shear steel strength of connection between anchor and channel for seismic design, normal-weight concrete	$V_{sc,y,seis}$	lb (kN)	- -	- -	8545 (38.0)	13040 (58.0)	13040 (58.0)	- -	- -
Nominal shear steel strength of connection between anchor and channel for seismic design, sand lightweight	$V_{sc,y,seis}$	lb (kN)	- -	- -	8095 (36.0)	10790 (48.0)	10790 (48.0)	- -	- -
Strength reduction factor for failure of connection between anchor and channel ¹	ϕ	-	0.75 (0.80)						

¹ The tabulated value of ϕ applies when the load combinations of Section 1605.1 of the 2021 IBC or Section 1605.2 of the 2018, 2015, or 2012 IBC, ACI 318 (-19 or -14) Section 5.3 or ACI 318-11 Section 9.2 are used. If the load combinations of ACI 318-11 Appendix C are used, the appropriate value of ϕ in parentheses must be used.

² Available only in carbon steel.

TABLE 10—STEEL LONGITUDINAL SHEAR STRENGTH DESIGN INFORMATION, JORDAHL JTA ANCHOR CHANNELS

Parameter	Symbol	Units	JTA				
			W40/22	W40+	W50/30	W50+	W53/34
Nominal shear steel strength of connection between channel lips and channel bolt, carbon steel	$V_{sl,x}$	lb (kN)	1370 (6.1)	1370 (6.1)	2965 (13.2)	2965 (13.2)	2965 (13.2)
Nominal shear steel strength of connection between channel lips and channel bolt for seismic design, carbon steel	$V_{sl,x,seis}$	lb (kN)	1170 (5.2)	1170 (5.2)	2070 (9.2)	2070 (9.2)	2070 (9.2)
Nominal shear steel strength of connection between channel lips and channel bolt, stainless steel	$V_{sl,x}$	lb (kN)	650 (2.9)	650 (2.9)	1055 (4.7)	1055 (4.7)	1055 (4.7)
Nominal shear steel strength of connection between channel lips and channel bolt for seismic design, stainless steel	$V_{sl,x,seis}$	lb (kN)	650 (2.9)	650 (2.9)	1055 (4.7)	1055 (4.7)	1055 (4.7)
Strength reduction factor for connection (periodic inspection) ¹ , carbon steel	ϕ	-	0.55 (0.60)		0.65 (0.70)		
Strength reduction factor for connection (continuous inspection) ¹ , carbon steel	ϕ	-	0.55 (0.60)		0.75 (0.80)		
Strength reduction factor for connection (periodic inspection) ¹ , stainless steel	ϕ	-	0.55 (0.60)				
Strength reduction factor for connection (continuous inspection) ¹ , stainless steel	ϕ	-	0.55 (0.60)				
Nominal shear steel strength of a single anchor, carbon steel	$V_{sa,x}$	lb (kN)	2745 (12.2)	4045 (18.0)	4270 (19.0)	5305 (23.6)	7690 (34.2)
Nominal shear steel strength of a single anchor for seismic design, carbon steel	$V_{sa,x,seis}$	lb (kN)	2360 (10.5)	2360 (10.5)	2990 (13.3)	2990 (13.3)	2990 (13.3)
Nominal shear steel strength of a single anchor, stainless steel	$V_{sa,x}$	lb (kN)	2745 (12.2)	4045 (18.0)	4270 (19.0)	5305 (23.6)	7690 (34.2)
Nominal shear steel strength of a single anchor for seismic design, stainless steel	$V_{sa,x,seis}$	lb (kN)	2745 (12.2)	2745 (12.2)	4270 (19.0)	4270 (19.0)	4270 (19.0)
Strength reduction factor for anchor failure ¹	ϕ	-	0.75 (0.80)				
Nominal shear steel strength of connection between anchor and channel, carbon steel	$V_{sc,x}$	lb (kN)	2745 (12.2)	4045 (18.0)	4270 (19.0)	4920 (21.9)	7690 (34.2)
Nominal shear steel strength of connection between anchor and channel for seismic design, carbon steel	$V_{sc,x,seis}$	lb (kN)	2360 (10.5)	2360 (10.5)	2990 (13.3)	2990 (13.3)	2990 (13.3)
Nominal shear steel strength of connection between anchor and channel, stainless steel	$V_{sc,x}$	lb (kN)	2745 (12.2)	4045 (18.0)	4270 (19.0)	4920 (21.9)	7690 (34.2)
Nominal shear steel strength of connection between anchor and channel for seismic design, stainless steel	$V_{sc,x,seis}$	lb (kN)	2745 (12.2)	2745 (12.2)	4270 (19.0)	4270 (19.0)	4270 (19.0)
Strength reduction factor for failure of connection between anchor and channel ¹	ϕ	-	0.75 (0.80)				

¹ The tabulated value of ϕ applies when the load combinations of Section 1605.1 of the 2021 IBC or Section 1605.2 of the 2018, 2015, or 2012 IBC, ACI 318 (-19 or -14) Section 5.3 or ACI 318-11 Section 9.2 are used. If the load combinations of ACI 318-11 Appendix C are used, the appropriate value of ϕ in parentheses must be used.

² Available only in carbon steel.

TABLE 11—STEEL PERPENDICULAR SHEAR STRENGTH DESIGN INFORMATION, JORDAHL JZA, JXA AND JXA-PC ANCHOR CHANNELS¹

Parameter	Symbol	Units	JZA	JXA				JXA-PC
			K41/22 ²	W29/20 ²	W38/23	W53/34	W64/44 ³	W53/34
Nominal shear steel strength for local failure of channel lips, carbon steel, normal-weight concrete	$V_{sl,y}$	lb (kN)	5490 (24.4)	4020 (17.9)	10845 (48.3)	22625 (100.6)	27000 (120.1)	22625 (100.6)
Nominal shear steel strength for local failure of channel lips, carbon steel, sand lightweight concrete	$V_{sl,y}$	lb (kN)	5490 (24.4)	4020 (17.9)	10070 (44.8)	16345 (72.7)	27000 (120.1)	- -
Nominal shear steel strength for local failure of channel lips for seismic design, carbon steel, normal-weight concrete	$V_{sl,y,seis}$	lb (kN)	5490 (24.4)	4020 (17.9)	10845 (48.3)	22625 (100.6)	27000 (120.1)	22625 (100.6)
Nominal shear steel strength for local failure of channel lips for seismic design, carbon steel, sand lightweight concrete	$V_{sl,y,seis}$	lb (kN)	5490 (24.4)	4020 (17.9)	10070 (44.8)	16345 (72.7)	27000 (120.1)	- -
Nominal shear steel strength for local failure of channel lips, stainless steel, normal-weight concrete	$V_{sl,y}$	lb (kN)	6290 (28.0)	- -	9485 (42.2)	20705 (92.1)	- -	- -
Nominal shear steel strength for local failure of channel lips, stainless steel, sand lightweight concrete	$V_{sl,y}$	lb (kN)	6290 (28.0)	- -	8365 (37.2)	14635 (65.1)	- -	- -
Nominal shear steel strength for local failure of channel lips for seismic design, stainless steel, normal-weight concrete	$V_{sl,y,seis}$	lb (kN)	6290 (28.0)	- -	8140 (36.2)	17510 (77.9)	- -	- -
Nominal shear steel strength for local failure of channel lips for seismic design, stainless steel, sand lightweight concrete	$V_{sl,y,seis}$	lb (kN)	6290 (28.0)	- -	7170 (31.9)	12365 (55.0)	- -	- -
Strength reduction factor for local failure of channel lips ²	ϕ	-	0.75 (0.80)					
Nominal shear steel strength of a single anchor, carbon steel, normal-weight concrete	$V_{sa,y}$	lb (kN)	5490 (24.4)	4020 (17.9)	10845 (48.3)	22625 (100.6)	27000 (120.1)	22625 (100.6)
Nominal shear steel strength of a single anchor, carbon steel, sand lightweight concrete	$V_{sa,y}$	lb (kN)	5490 (24.4)	4020 (17.9)	10070 (44.8)	16345 (72.7)	27000 (120.1)	- -
Nominal shear steel strength of a single anchor for seismic design, carbon steel, normal-weight concrete	$V_{sa,y,seis}$	lb (kN)	5490 (24.4)	4020 (17.9)	10845 (48.3)	22625 (100.6)	27000 (120.1)	22625 (100.6)
Nominal shear steel strength of a single anchor for seismic design, carbon steel, sand lightweight concrete	$V_{sa,y,seis}$	lb (kN)	5490 (24.4)	4020 (17.9)	10070 (44.8)	16345 (72.7)	27000 (120.1)	- -
Nominal shear steel strength of a single anchor, stainless steel, normal-weight concrete	$V_{sa,y}$	lb (kN)	6290 (28.0)	- -	9485 (42.2)	20705 (92.1)	- -	- -
Nominal shear steel strength of a single anchor, stainless steel, sand lightweight concrete	$V_{sa,y}$	lb (kN)	6290 (28.0)	- -	9485 (42.2)	20705 (92.1)	- -	- -
Nominal shear steel strength of a single anchor for seismic design, stainless steel, normal-weight concrete	$V_{sa,y,seis}$	lb (kN)	6290 (28.0)	- -	8140 (36.2)	17510 (77.9)	- -	- -
Nominal shear steel strength of a single anchor for seismic design, stainless steel, sand lightweight concrete	$V_{sa,y,seis}$	lb (kN)	6290 (28.0)	- -	8140 (36.2)	17510 (77.9)	- -	- -
Strength reduction factor for anchor failure ²	ϕ	-	0.75 (0.80)					

TABLE 11—STEEL PERPENDICULAR SHEAR STRENGTH DESIGN INFORMATION, JORDAHL JZA AND JXA ANCHOR CHANNELS (CONTINUED)

Parameter	Symbol	Units	JZA	JXA				JXA-PC
			K41/22 ²	W29/20 ²	W38/23	W53/34	W64/44 ³	W53/34
Nominal shear steel strength of connection between anchor and channel, normal-weight concrete	$V_{sc,y}$	lb (kN)	5490 (24.4)	4020 (17.9)	10845 (48.3)	22625 (100.6)	27000 (120.1)	22625 (100.6)
Nominal shear steel strength of connection between anchor and channel, sand lightweight concrete	$V_{sc,y}$	lb (kN)	5490 (24.4)	4020 (17.9)	10070 (44.8)	16345 (72.7)	27000 (120.1)	- -
Nominal shear steel strength of connection between anchor and channel for seismic design, normal-weight concrete	$V_{sc,y,seis}$	lb (kN)	5490 (24.4)	4020 (17.9)	10845 (48.3)	22625 (100.6)	27000 (120.1)	22625 (100.6)
Nominal shear steel strength of connection between anchor and channel for seismic design, sand lightweight	$V_{sc,y,seis}$	lb (kN)	5490 (24.4)	4020 (17.9)	10070 (44.8)	16345 (72.7)	27000 (120.1)	- -
Nominal shear steel strength of connection between anchor and channel, stainless steel, normal-weight concrete	$V_{sc,y}$	lb (kN)	6290 (28.0)	- -	9485 (42.2)	20705 (92.1)	- -	- -
Nominal shear steel strength of connection between anchor and channel, stainless steel, sand lightweight concrete	$V_{sc,y}$	lb (kN)	6290 (28.0)	- -	9485 (42.2)	20705 (92.1)	- -	- -
Nominal shear steel strength of connection between anchor and channel for seismic design, stainless steel, normal-weight concrete	$V_{sc,y,seis}$	lb (kN)	6290 (28.0)	- -	8140 (36.2)	17510 (77.9)	- -	- -
Nominal shear steel strength of connection between anchor and channel for seismic design, stainless steel, sand lightweight	$V_{sc,y,seis}$	lb (kN)	6290 (28.0)	- -	8140 (36.2)	17510 (77.9)	- -	- -
Strength reduction factor for failure of connection between anchor and channel ²	ϕ	-	0.75 (0.80)					

¹ The tabulated value of ϕ applies when the load combinations of Section 1605.2 1605.1 of the 2021 IBC or Section of the 2018, 2015, or 2012 IBC, ACI 318 (-19 or -14) Section 5.3 or ACI 318-11 Section 9.2 are used. If the load combinations of ACI 318-11 Appendix C are used, the appropriate value of ϕ in parentheses must be used.

² Available only with round anchors.

³ Available only with l-anchors.

TABLE 12—STEEL LONGITUDINAL SHEAR STRENGTH DESIGN INFORMATION, JORDAHL JZA, JXA, AND JXA-PC ANCHOR CHANNELS

Parameter	Symbol	Units	JZA	JXA				JXA-PC
			K41/22 ²	W29/20 ²	W38/23	W53/34	W64/44 ³	W53/34
Nominal shear steel strength of connection between channel lips and channel bolt, carbon steel	$V_{sl,x}$	lb (kN)	2260 (10.0)	2690 (12.0)	4360 (19.4)	7320 (32.6)	14500 (64.5)	10795 (48.0)
Nominal shear steel strength of connection between channel lips and channel bolt for seismic design, carbon steel	$V_{sl,x,seis}$	lb (kN)	2260 (10.0)	2690 (12.0)	4360 (19.4)	7320 (32.6)	14500 (64.5)	10795 (48.0)
Nominal shear steel strength of connection between channel lips and channel bolt, stainless steel	$V_{sl,x}$	lb (kN)	2400 (10.7)	-	2670 (11.9)	5125 (22.8)	-	-
Nominal shear steel strength of connection between channel lips and channel bolt for seismic design, stainless steel	$V_{sl,x,seis}$	lb (kN)	2400 (10.7)	-	2670 (11.9)	5125 (22.8)	-	-
Strength reduction factor for connection (periodic inspection) ¹	ϕ	-	0.75 (0.80)	0.65 (0.70)	0.75 (0.80)			
Strength reduction factor for connection (continuous inspection) ¹	ϕ	-	0.75 (0.80)	0.75 (0.80)	0.75 (0.80)			
Nominal shear steel strength of a single anchor, carbon steel	$V_{sa,x}$	lb (kN)	3430 (15.3)	3430 (15.3)	4225 (18.8)	7710 (34.3)	15510 (69.0)	11420 (50.8)
Nominal shear steel strength of a single anchor for seismic design, carbon steel	$V_{sa,x,seis}$	lb (kN)	3430 (15.3)	3430 (15.3)	4225 (18.8)	7710 (34.3)	15510 (69.0)	11420 (50.8)
Nominal shear steel strength of a single anchor, stainless steel	$V_{sa,x}$	lb (kN)	3430 (15.3)	-	4225 (18.8)	7710 (34.3)	-	-
Nominal shear steel strength of a single anchor for seismic design, stainless steel	$V_{sa,x,seis}$	lb (kN)	3430 (15.3)	-	4225 (18.8)	7710 (34.3)	-	-
Strength reduction factor for anchor failure ¹	ϕ	-	0.75 (0.80)					
Nominal shear steel strength of connection between anchor and channel, carbon steel	$V_{sc,x}$	lb (kN)	1960 (8.7)	2610 (11.6)	4225 (18.8)	7710 (34.3)	14345 (63.8)	11420 (50.8)
Nominal shear steel strength of connection between anchor and channel for seismic design, carbon steel	$V_{sc,x,seis}$	lb (kN)	1960 (8.7)	2610 (11.6)	4225 (18.8)	7710 (34.3)	14345 (63.8)	11420 (50.8)
Nominal shear steel strength of connection between anchor and channel, stainless steel	$V_{sc,x}$	lb (kN)	2430 (10.8)	-	4225 (18.8)	6610 (29.4)	-	-
Nominal shear steel strength of connection between anchor and channel for seismic design, stainless steel	$V_{sc,x,seis}$	lb (kN)	2440 (10.8)	-	4225 (18.8)	6610 (29.4)	-	-
Strength reduction factor for failure of connection between anchor and channel ¹	ϕ	-	0.75 (0.80)					

¹ The tabulated value of ϕ applies when the load combinations of Section 1605.1 of the 2021 IBC or Section 1605.2 of the 2018, 2015, or 2012 IBC, ACI 318 (-19 or -14) Section 5.3 or ACI 318-11 Section 9.2 are used. If the load combinations of ACI 318-11 Appendix C are used, the appropriate value of ϕ in parentheses must be used.

² Available only with round anchors.

³ Available only with I-anchors.

TABLE 13—CONCRETE SHEAR STRENGTH DESIGN INFORMATION, JORDAHL JTA ANCHOR CHANNELS

Parameter	Symbol	Units	JTA						
			K28/15	K38/17	W40/22 W40+	W50/30 W50+	W53/34	W55/42	W72/48
Factor to account for the influence of channel size and anchor diameter on concrete edge breakout strength in shear, round anchors and I-anchors	$\alpha_{ch,V}$	lb ^{0.5} / in ^{0.33} (N ^{0.5} / mm ^{0.33})	5.5 (4.0)	10.5 (7.5)	10.5 (7.5)	10.5 (7.5)	10.5 (7.5)	10.5 (7.5)	10.5 (7.5)
Factor to account for the influence of channel size and anchor diameter on concrete edge breakout strength in shear, T-anchors	$\alpha_{ch,V}$	lb ^{0.5} / in ^{0.33} (N ^{0.5} / mm ^{0.33})	- -	- -	9.5 ³ (6.8 ³)	10.5 (7.5)	10.5 (7.5)	9.5 (6.8)	- -
Exponent in Eq. (37) to account for the influence of the member depth on the concrete edge breakout strength	β_1	-	0.5						
Coefficient for pryout strength, round and I-anchors	k_{cp}	-	1.0	2.0					
Coefficient for pryout strength, T-anchors	k_{cp}	-	1.0 ²						
Strength reduction factor for shear, concrete failure modes ¹	ϕ	-	0.70						

¹The tabulated value of ϕ applies when both the load combinations of Section 1605.1 of the 2021 IBC or Section 1605.2 of the 2018, 2015, or 2012 IBC, ACI 318 (-19 or -14) Section 5.3 or ACI 318-11 Section 9.2 are used and the requirements of ACI 318-19 17.5.3, ACI 318-14 17.3.3(c) or ACI 318-11 D.4.3(c), as applicable, for Condition B are met. Condition B applies where supplementary reinforcement is not provided. For installations where complying supplementary reinforcement can be verified, the ϕ factors described in ACI 318-19 17.5.3, ACI 318-14 17.3.3(c) or ACI 318-11 D.4.3(c), as applicable, for Condition A are allowed. If the load combinations of ACI 318-11 Appendix C are used, the appropriate value of ϕ must be determined in accordance with ACI 318-11 D.4.4(c).

²The tabulated value of k_{cp} can be increased to 2.0 if $h_{ef} \geq 2.5$ in. (63.5 mm).

³For JTA W 40+ $\alpha_{ch,V} = 10.5 \text{ lb}^{0.5}/\text{in}^{0.33}$ (7.5 N^{0.5}/mm^{0.33}).

TABLE 14—CONCRETE SHEAR STRENGTH DESIGN INFORMATION, JORDAHL JZA, JXA AND JXA-PC ANCHOR CHANNELS

Parameter	Symbol	Units	JZA	JXA				JXA-PC
			K41/22	W29/20	W38/23	W53/34	W64/44	W53/34
Factor to account for the influence of channel size and anchor diameter on concrete edge breakout strength in shear, round anchors	$\alpha_{ch,V}$	lb ^{0.5} / in ^{0.33} (N ^{0.5} / mm ^{0.33})	10.5 (7.5)	8.2 (5.9)	10.5 (7.5)	10.5 (7.5)	- -	10.5 (7.5)
Factor to account for the influence of channel size and anchor diameter on concrete edge breakout strength in shear, I- and T-anchors	$\alpha_{ch,V}$	lb ^{0.5} / in ^{0.33} (N ^{0.5} / mm ^{0.33})	- -	- -	7.7 (5.5)	10.5 (7.5)	10.5 (7.5)	- -
Exponent in Eq. (37) to account for the influence of the member depth on the concrete edge breakout strength	β_1	-	0.5					
Coefficient for pryout strength, round and I-anchors	k_{cp}	-	2.0				-	2.0
Coefficient for pryout strength, T-anchors	k_{cp}	-	-	-	1.0 ²			-
Strength reduction factor for shear, concrete failure modes ¹	ϕ	-	0.70					

¹The tabulated value of ϕ applies when both the load combinations of Section 1605.1 of the 2021 IBC or Section 1605.2 of the 2018, 2015, or 2012 IBC, ACI 318 (-19 or -14) Section 5.3 or ACI 318-11 Section 9.2 are used and the requirements of ACI 318-19 17.5.3, ACI 318-14 17.3.3(c) or ACI 318-11 D.4.3(c), as applicable, for Condition B are met. Condition B applies where supplementary reinforcement is not provided. For installations where complying supplementary reinforcement can be verified, the ϕ factors described in ACI 318-19 17.5.3, ACI 318-14 17.3.3(c) or ACI 318-11 D.4.3(c), as applicable, for Condition A are allowed. If the load combinations of ACI 318-11 Appendix C are used, the appropriate value of ϕ must be determined in accordance with ACI 318-11 D.4.4(c).

²The tabulated value of k_{cp} can be increased to 2.0 if $h_{ef} \geq 2.5$ in. (63.5 mm).

TABLE 15—STEEL TENSION STRENGTH DESIGN INFORMATION, JORDAHL CHANNEL BOLTS FOR JTA CHANNELS

Parameter	Symbol	Grade/ material	Units	JD, JH, JC, JKC, JB, JKB, JA								
				M6	M8	M10	M12	M16	M20	M24	M27	M30
Nominal tensile strength	N_{ss}	4.6	lb (kN)	1800 (8.0)	3280 (14.6)	5215 (23.2)	7575 (33.7)	14120 (62.8)	22030 (98.0)	31745 (141.2)	41275 (183.6)	50450 (224.4)
		8.8	lb (kN)	- -	6585 (29.3)	8860 (39.4)	12860 (57.2)	28235 (125.6)	45715 (203.0)	63485 (282.4)	- -	- -
		A4-50 HCR-50	lb (kN)	- -	- -	5195 (23.1)	7555 (33.6)	14075 (62.6)	21985 (97.8)	- -	- -	- -
		A4-70 HCR-70 FA-70	lb (kN)	- -	5755 (25.6)	9130 (40.6)	13265 (59.0)	24055 (107.0)	38555 (171.5)	- -	- -	- -
Nominal tensile strength for seismic design ¹	$N_{ss,seis}$	8.8	lb (kN)	- -	- -	- -	12860 (57.2)	28235 (125.6)	45715 (203.0)	- -	- -	- -
		A4-70 HCR-70 FA-70	lb (kN)	- -	- -	- -	13265 (59.0)	24055 (107.0)	38555 (171.5)	- -	- -	- -
Strength reduction factor for tension, steel failure modes ²	ϕ	-	-	0.65 (0.75)								

¹ JKB and JKC channel bolts

²The tabulated value of ϕ applies when the load combinations of Section 1605.1 of the 2021 IBC or Section 1605.2 of the 2018, 2015, or 2012 IBC, ACI 318 (-19 or -14) Section 5.3 or ACI 318-11 Section 9.2 are used. If the load combinations of ACI 318-11 Appendix C are used, the appropriate value of ϕ in parentheses must be used.

TABLE 16—STEEL TENSION STRENGTH DESIGN INFORMATION, JORDAHL TOOTHED BOLTS FOR JZA, JXA, AND JXA-PC ANCHOR CHANNELS

Parameter	Symbol	Grade/ material	Units	JZS			JXD, JXH, JXB, JXE			
				M12	M16	M10	M12	M16	M20	M24
Nominal tensile strength	N_{ss}	8.8	lb (kN)	10995 (48.9)	22235 (98.9)	10430 (46.4)	15160 (67.4)	28235 (125.6)	44065 (196.0)	63485 (282.4)
Nominal tensile strength for seismic design	$N_{ss,seis}$			10995 (48.9)	22235 (98.9)	10430 (46.4)	15160 (67.4)	28235 (125.6)	44065 (196.0)	63485 (282.4)
Nominal tensile strength	N_{ss}	A4-50	lb (kN)	7555 (33.6)	14075 (62.6)	- -	- -	- -	- -	- -
Nominal tensile strength for seismic design	$N_{ss,seis}$			7555 (33.6)	14075 (62.6)	- -	- -	- -	- -	- -
Nominal tensile strength	N_{ss}	A4-70	lb (kN)	- -	- -	- -	13265 (59.0)	24710 (109.9)	38555 (171.5)	- -
Nominal tensile strength for seismic design	$N_{ss,seis}$			- -	- -	- -	13265 (59.0)	24710 (109.9)	38555 (171.5)	- -
Strength reduction factor for tension, steel failure modes ¹	ϕ	-	-	0.65(0.75)						

¹The tabulated value of ϕ applies when the load combinations of Section 1605.1 of the 2021 IBC or Section 1605.2 of the 2018, 2015, or 2012 IBC, ACI 318 (-19 or -14) Section 5.3 or ACI 318-11 Section 9.2 are used. If the load combinations of ACI 318-11 Appendix C are used, the appropriate value of ϕ in parentheses must be used.

TABLE 17—STEEL SHEAR STRENGTH DESIGN INFORMATION, JORDAHL CHANNEL BOLTS FOR JTA ANCHOR CHANNELS

Parameter	Symbol	Grade/ material	Units	Channel bolt sizes								
				M6	M8	M10	M12	M16	M20	M24	M27	M30
Nominal shear strength of a channel bolt	V_{ss}	4.6	lb (kN)	1080 (4.8)	1980 (8.8)	3125 (13.9)	4540 (20.2)	8475 (37.7)	13220 (58.8)	19040 (84.7)	24775 (110.2)	30260 (134.6)
		8.8	lb (kN)	- -	3955 (17.6)	6250 (27.8)	9080 (40.4)	16950 (75.4)	27425 (122.0)	39545 (175.9)	- -	- -
		A4-50 HCR-50	lb (kN)	- -	- -	3125 (13.9)	4540 (20.2)	8475 (37.7)	13220 (58.8)	- -	- -	- -
		A4-70 HCR-70 FA-70	lb (kN)	- -	3460 (15.4)	5485 (24.4)	7960 (35.4)	14815 (65.9)	23135 (102.9)	- -	- -	- -
Nominal shear strength for seismic design ¹	$V_{ss,seis}$	8.8	lb (kN)	- -	- -	- -	9090 (40.4)	16950 ³ (75.4) ³	27425 (122.0)	- -	- -	- -
		A4-70 HCR-70 FA-70	lb (kN)	- -	- -	- -	7960 (35.4)	14815 ³ (65.9) ³	23135 (102.9)	- -	- -	- -
Nominal flexural strength of the channel bolt	M_{ss}^0	4.6	in-lb (Nm)	55 (6.3)	135 (15.0)	265 (29.9)	465 (52.3)	1175 (133)	2290 (259)	3965 (448)	5900 (667)	7955 (899)
		8.8	in-lb (Nm)	- -	265 (30.0)	530 (59.8)	930 (105)	2355 (266)	4795 (542)	8250 (932)	- -	- -
		A4-50 HCR-50	in-lb (Nm)	- -	- -	265 (29.9)	465 (52.3)	1175 (133)	2290 (259)	- -	- -	- -
		A4-70 HCR-70 FA-70	in-lb (Nm)	- -	235 (26.3)	465 (52.4)	810 (91.6)	2055 (232)	4020 (454)	- -	- -	- -
Nominal flexural strength of the bolt for seismic design ¹	$M_{ss,seis}^0$	8.8	lb (kN)	- -	- -	- -	930 (105)	2355 (266)	4795 (542)	- -	- -	- -
		A4-70 HCR-70 FA-70	lb (kN)	- -	- -	- -	810 (91.6)	2055 (232)	4020 (454)	- -	- -	- -
Strength reduction factor for shear, steel failure modes ²	ϕ	-	-	0.60 (0.65)								

¹ JKB and JKC channel bolts.

²The tabulated value of ϕ applies when the load combinations of Section 1605.1 of the 2021 IBC or Section 1605.2 of the 2018, 2015, or 2012 IBC, ACI 318 (-19 or -14) Section 5.3 or ACI 318-11 Section 9.2 are used. If the load combinations of ACI 318-11 Appendix C are used, the appropriate value of ϕ in parentheses must be used.

³ For JKC M16 $V_{ss,seis}$ = 9090 lb (40.4 kN).

TABLE 18—STEEL SHEAR STRENGTH DESIGN INFORMATION, JORDAHL TOOTHED BOLTS FOR JZA, JXA AND JXA-PC ANCHOR CHANNELS

Parameter	Symbol	Grade/ material	Units	JZS		JXD, JXH, JXB, JXE				
				M12	M16	M10	M12	M16	M20	M24
Nominal shear strength	V_{ss}	8.8	lb (kN)	9105 (40.5)	16950 (75.4)	6250 (27.8)	9105 (40.5)	16950 (75.4)	27425 (122.0)	39545 (175.9)
Nominal shear strength for seismic design	$V_{ss,seis}$			9105 (40.5)	16950 (75.4)	6250 (27.8)	9105 (40.5)	16950 (75.4)	27425 (122.0)	39545 (175.9)
Nominal shear strength	V_{ss}	A4-50	lb (kN)	4540 (20.2)	8475 (37.7)	-	-	-	-	-
Nominal shear strength for seismic design	$V_{ss,seis}$			4540 (20.2)	8475 (37.7)	-	-	-	-	-
Nominal shear strength	V_{ss}	A4-70	lb (kN)	-	-	-	7960 (35.4)	14815 (65.9)	23135 (102.9)	-
Nominal shear strength for seismic design	$V_{ss,seis}$			-	-	-	7960 (35.4)	14815 (65.9)	23135 (102.9)	-
Nominal flexural strength of the bolt	M^o_{ss}	8.8	in-lb (Nm)	930 (105)	2355 (266)	530 (59.8)	930 (105)	2355 (266)	4800 (542)	8250 (932)
Nominal flexural strength of the bolt for seismic design	$M^o_{ss,seis}$			930 (105)	2355 (266)	530 (59.8)	930 (105)	2355 (266)	4800 (542)	8250 (932)
Nominal flexural strength of the bolt	M^o_{ss}	A4-50	in-lb (Nm)	460 (52.2)	1170 (132.4)	-	-	-	-	-
Nominal flexural strength of the bolt for seismic design	$M^o_{ss,seis}$			460 (52.2)	1170 (132.4)	-	-	-	-	-
Nominal flexural strength of the bolt	M^o_{ss}	A4-70	in-lb (Nm)	-	-	-	810 (91.6)	2055 (232.3)	4015 (453.8)	-
Nominal flexural strength of the bolt for seismic design	$M^o_{ss,seis}$			-	-	-	810 (91.6)	2055 (232.3)	4015 (453.8)	-
Strength reduction factor for steel failure modes ¹	ϕ	-	-	0.60(0.65)						

¹The tabulated value of ϕ applies when the load combinations of Section 1605.1 of the 2021 IBC or Section 1605.2 of the 2018, 2015, or 2012 IBC, ACI 318 (-19 or -14) Section 5.3 or ACI 318-11 Section 9.2 are used. If the load combinations of ACI 318-11 Appendix C are used, the appropriate value of ϕ in parentheses must be used.

TABLE 19—JORDAHL CHANNEL BOLT INSTALLATION TORQUES FOR GENERAL INSTALLATIONS

Anchor channel size	Channel bolt grade/material	Units	Channel bolt sizes								
			M6	M8	M10	M12	M16	M20	M24	M27	M30
JTA K28/15	4.6, 8.8, A4-50, HCR-50, A4-70, HCR-70, FA-70	ft-lb (N-m)	2 (3)	5 (7)	10 (13)	11 (15)	- -	- -	- -	- -	- -
JTA K38/17		ft-lb (N-m)	- -	- -	10 (13)	18 (24)	22 (30)	- -	- -	- -	- -
JTA W40/22 JTA W40+		ft-lb (N-m)	- -	- -	10 (13)	18 ¹ (24 ¹)	22 ¹ (30 ¹)	- -	- -	- -	- -
JTA W50/30 JTA W50+		ft-lb (N-m)	- -	- -	10 (13)	18 (24)	40 ² (55 ²)	51 ² (70 ²)	- -	- -	- -
JTA W53/34		ft-lb (N-m)	- -	- -	10 (13)	18 (24)	40 ² (55 ²)	85 ² (115 ²)	- -	- -	- -
JTA W55/42		ft-lb (N-m)	- -	- -	10 (13)	18 (24)	40 (55)	85 (115)	133 (180)	- -	- -
JTA W72/48		ft-lb (N-m)	- -	- -	- -	- -	- -	85 (115)	147 (200)	220 (300)	255 (345)
JZA K41/22		8.8, A4-50	ft-lb (N-m)	- -	- -	- -	52 (70)	89 (120)	- -	- -	- -
JXA W29/20	8.8, A4-70	ft-lb (N-m)	- -	- -	22 (30)	52 (70)	- -	- -	- -	- -	- -
JXA W38/23		ft-lb (N-m)	- -	- -	- -	52 (70)	89 (120)	- -	- -	- -	- -
JXA W53/34		ft-lb (N-m)	- -	- -	- -	- -	133 (180)	221 (300)	- -	- -	- -
JXA W64/44		ft-lb (N-m)	- -	- -	- -	- -	- -	221 (300)	258 (350)	- -	- -

¹ Installation torque for JC bolts, JKC bolts require steel-steel contact see [Table 20](#).

² Installation torque for JB bolts, JKB bolts require steel-steel contact see [Table 20](#).

TABLE 20—JORDAHL CHANNEL BOLT INSTALLATION TORQUES FOR STEEL-TO-STEEL CONTACT INSTALLATIONS

Anchor channel size	Channel bolt grade/material	Units	Channel bolt sizes								
			M6	M8	M10	M12	M16	M20	M24	M27	M30
JTA K28/15, JTA K38/17, JTA W40/22, JTA W40+, JTA W50/30, JTA W50+, JTA W53/34, JTA W55/42, JTA W72/48	4.6	ft-lb (N-m)	2 (3)	6 (8)	11 (15)	18 (25)	48 (65)	96 (130)	170 (230)	250 (340)	340 (460)
	A4-50, HCR-50	ft-lb (N-m)	- -	- -	10 (13)	18 (24)	44 (60)	85 (115)	- -	- -	- -
	8.8	ft-lb (N-m)	- -	15 (20)	29 (40)	51 (70)	133 (180)	265 (360)	457 (620)	- -	- -
	A4-70, HCR-70, FA-70	ft-lb (N-m)	- -	11 (15)	22 (30)	51 ¹ /37 (70 ¹ /50)	133 ¹ /96 (180 ¹ /130)	184 (250)	- -	- -	- -
JZA K41/22	8.8, A4-50	ft-lb (N-m)	- -	- -	- -	52 (70)	89 (120)	- -	- -	- -	- -
JXA W 9/20	8.8	ft-lb (N-m)	- -	- -	29 (40)	52 (70)	- -	- -	- -	- -	- -
JXA W38/23	8.8	ft-lb (N-m)	- -	- -	- -	52 (70)	133 (180)	- -	- -	- -	- -
	A4-70	ft-lb (N-m)	- -	- -	- -	52 (70)	96 (130)	- -	- -	- -	- -
JXA W53/34	8.8, A4-70	ft-lb (N-m)	- -	- -	- -	- -	133 (180)	265 (360)	- -	- -	- -
JXA W 64/44	8.8	ft-lb (N-m)	- -	- -	- -	- -	- -	265 (360)	332 (450)	- -	- -

¹ Installation torque for JKB and JKC channel bolts.

TABLE 21—MATERIAL SPECIFICATIONS

Component	Carbon steel with coating		Stainless steel Material
	Material	Surface	
Anchor	Carbon steel	Hot-dip galvanized ≥ 55 μm	Stainless steel
Channel	Carbon steel	Hot-dip galvanized ≥ 55 μm	Stainless steel
Bolt	Carbon steel; grade 4.6, 8.8 according to ISO 898-1	Hot-dip galvanized ≥ 50 μm or electroplated (“G”) ≥ 5 μm	Stainless steel; grade 50, 70 according to ISO 3506-1
Washer ¹	Carbon steel; class A; grade 200HV according to ISO 7089 and ISO 7093-1	Hot-dip galvanized ≥ 50 μm or electroplated ≥ 5 μm	Stainless steel; class A4 according to ISO 3506-1
Nut	Carbon steel; class A, B; grade 5, 8 according to ISO 4032	Hot-dip galvanized ≥ 50 μm or electroplated ≥ 5 μm	Stainless steel; class A4; grade 50, 70 according to ISO 3506-1

¹Not included in delivery.

TABLE 22—WASHER REQUIREMENTS FOR STAND-OFF INSTALLATIONS¹

Anchor channel size	Channel bolt type	Channel bolt sizes							
		M8	M10	M12	M16	M20	M24	M27	M30
JTA K28/15	JD	ISO 7093-1	ISO 7093-1	ISO 7089	-	-	-	-	-
JTA K38/17	JH	-	38 x 38 x 5	ISO 7093-1	ISO 7093-1	-	-	-	-
JTA W40/22, JTA W40+	JC, JKC	-	38 x 38 x 5	ISO 7093-1	ISO 7093-1	-	-	-	-
JTA W50/30, JTA W50+	JB, JKB	-	50 x 50 x 6	50 x 50 x 6	50 x 50 x 6	50 x 50 x 6	-	-	-
JTA W53/34	JB, JKB	-	50 x 50 x 6	50 x 50 x 6	50 x 50 x 6	50 x 50 x 6	-	-	-
JTA W55/42	JB	-	50 x 50 x 6	50 x 50 x 6	50 x 50 x 6	50 x 50 x 6	50 x 50 x 6	-	-
JTA W72/48	JA	-	-	-	-	70 x 70 x 8	70 x 70 x 8	70 x 70 x 8	70 x 70 x 8
JZA K41/22	JZS	-	-	38 x 38 x 5	38 x 38 x 5	-	-	-	-
JXA W29/20	JXD	-	ISO 7093-1	ISO 7089	-	-	-	-	-
JXA W38/23	JXH	-	-	38 x 38 x 5	38 x 38 x 5	-	-	-	-
JXA W53/34	JXB	-	-	-	50 x 50 x 6	50 x 50 x 6	-	-	-
JXA W64/44	JXE	-	-	-	-	50 x 50 x 6	50 x 50 x 6	-	-

¹Dimensions provided are for square washers, width x length x thickness, in mm.

TABLE 23—JORDAHL JTA ANCHOR CHANNEL DESIGNATION ALTERNATIVES

Parameter	JTA								
	K28/15	K38/17	W40/22	W40+	W50/30	W50+	W53/34	W55/42	W72/48
Marking on anchor head	J 28	J 38	J 40	J 40+	J 50	J 50+	J 53	J 55	J 72
Print or label on channel lip or bottom	JTA K28/15	JTA K38/17	JTA W40/22	JTA W40+	JTA W50/30	JTA W50+	JTA W53/34	JTA W55/42	JTA W72/48

TABLE 24—JORDAHL JZA, JXA AND JXA-PC ANCHOR CHANNEL DESIGNATION ALTERNATIVES

Parameter	JZA	JXA				JXA-PC
	K41/22	W29/20	W38/23	W53/34	W64/44	W53/34
Marking on anchor head	J 40	J 29	J 38	J 53	J 64	-
Print or label on channel lip or bottom	JZA K41/22	JZA W29/20	JXA W38/23	JXA W53/34	JXA W64/44	JXA-PC W53/34

1. Fixing anchor channel

Install the channel surface flush and fix the channel rigidly to the formwork or to the reinforcement.

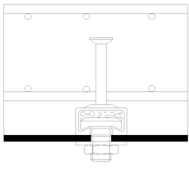
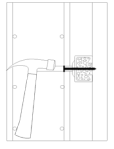
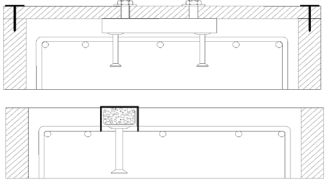
	<p>a) Fixing to steel formwork With JORDAHL T-bolts and nuts, with rivets, cramps or with magnet fixings.</p> <p>or</p>
	<p>b) Fixing to timber formwork With nails through the pre punched holes in the back of the channels and with staples.</p> <p>or</p>
	<p>c) Fixing to anchor channels at the top</p> <ul style="list-style-type: none"> • To timber batten on the side formwork (e.g. with JORDAHL T-bolts). • Fixing from above directly to the reinforcement or to a mounting reinforcing bar, attach the channel by wire

2. Pouring concrete and regular compacting of concrete

Compact the concrete properly around the channel and the anchors.

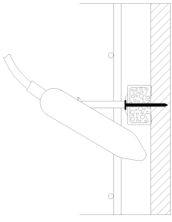
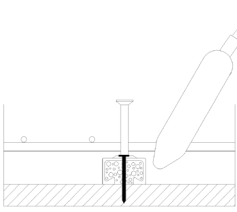
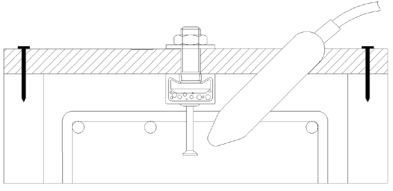
	or		or	
a) at side of member		b) at bottom of member		c) at top of member

3. Removing the infill

Clean the channel on the outside after removing the formwork

	<p>a) PS foam infill With a hammer or a hook.</p> <p>or</p>
	<p>b) PE foam infill By hand or with help of a screw driver in one piece.</p>

FIGURE 8-3—MANUFACTURERS PRINTED INSTALLATION INSTRUCTIONS (MPII) FOR JORDAHL ANCHOR CHANNELS

4. Fastening the JORDAHL T-bolt to the JORDAHL anchor channel

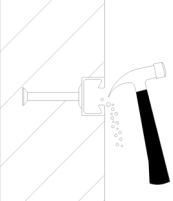
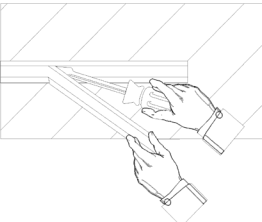
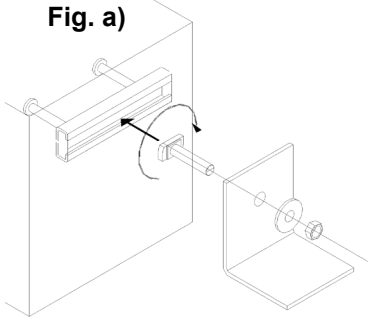

Fig. a)

a) Installation torques (general)

1. Insert the JORDAHL T-bolt into the channel slot at any point along the channel length (Fig. a).
2. Turn the channel bolt 90° clockwise and the head of the channel bolt locks into position (Fig. a).
3. Do not mount the channel bolt closer than 25 mm from the end of the channel.
4. Use washers between fixture and nut (Fig. a).
5. Check the correct fit of the channel bolt. The groove on the shank end of the channel bolt must be perpendicular to the channel longitudinal axis.
6. Tighten the nuts by a calibrated torque wrench (see Fig. b) to the installation torque (Table b). The installation torque shall not be exceeded.

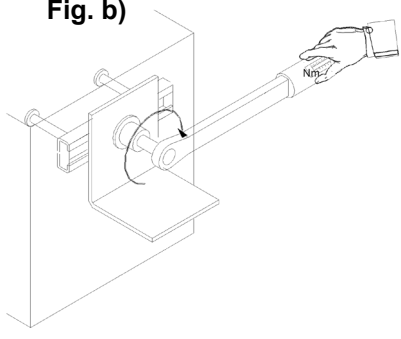

Fig. b)

Table a)

Strength grade	Anchor channel		T _{inst,g} [Nm]								
			M6	M8	M10	M12	M16	M20	M24	M27	M30
Carbon steel (CS) 4.6, 8.8; Stainless steel (SS) 50, 70	JTA	K28/15	3	8	13	15	-	-	-	-	-
		K38/17	-	-	15	25	40	-	-	-	-
		W40/22 W40+	-	-	15	25	45	-	-	-	-
		W50/30 W50+	-	-	15	25	60	75	-	-	-
		W53/34	-	-	15	25	60	120	-	-	-
		W55/42	-	-	15	25	60	120	200	-	-
	W72/48	-	-	-	-	-	120	200	300	380	
	JZA	K40/22	-	-	-	70	120	-	-	-	-
	JXA JXA-PC	W29/20	-	-	30	70	-	-	-	-	-
		W38/23	-	-	-	70	120	-	-	-	-
W53/34		-	-	-	-	180	300	-	-	-	
W64/44		-	-	-	-	-	300	350	-	-	

OR

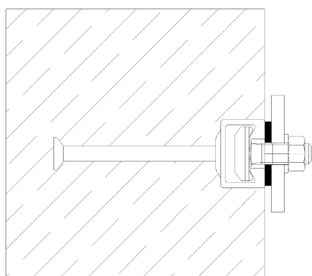

Fig. c)

b) Installation torques (steel-steel contact)

1. Insert the JORDAHL T-bolt into the channel slot at any point along the channel length (Fig. a).
2. Turn the channel bolt 90° clockwise and the head of the channel bolt locks into position (Fig. a).
3. Do not mount the channel bolt closer than 25 mm from the end of the channel.
4. Use washers between channel and fixture to avoid bearing of the fixture against the concrete (Fig. b).
5. Use washers between fixture and nut (Fig. a).
6. Check the correct fit of the channel bolt. The groove on the shank end of the channel bolt must be perpendicular to the channel longitudinal axis.

Tighten the nuts by a calibrated torque wrench (see Fig. b) to the installation torque (Table a). The installation torque shall not be exceeded.

Table b)

Anchor channel		Strength grade	T _{inst,s} [Nm]								
			M6	M8	M10	M12	M16	M20	M24	M27	M30
JTA	K28/15, K38/17, W40/22, W40+, W50/30, W50+, W53/34, W55/42, W72/48	CS 4.6	3	8	15	25	65	130	230	340	460
		SS 50	-	-	13	24	60	115	-	-	-
	CS 8.8	-	20	40	70	180	360	620	-	-	
	SS 70	-	15	30	50 / 70 ¹⁾	130 / 180 ¹⁾	250 / 360 ¹⁾	-	-	-	
JZA	K41/22	CS 8.8, SS 50	-	-	-	70	120	-	-	-	-
JXA JXA-PC	W29/20	CS 8.8	-	-	40	70	-	-	-	-	-
	W38/23	CS 8.8	-	-	-	70	180	-	-	-	-
		SS 70	-	-	-	70	130	-	-	-	-
	W53/34	CS 8.8, SS 70	-	-	-	-	180	360	-	-	-
	W64/44	CS 8.8	-	-	-	-	-	360	450	-	-

¹⁾ JKB/JKC channel bolts

FIGURE 8-3—MANUFACTURERS PRINTED INSTALLATION INSTRUCTIONS (MPII) FOR JORDAHL ANCHOR CHANNELS (CONT.)

DIVISION: 03 00 00—CONCRETE
Section: 03 15 19—Cast-In Concrete Anchors
Section: 03 16 00—Concrete Anchors

REPORT HOLDER:

JORDAHL

EVALUATION SUBJECT:

JORDAHL ANCHOR CHANNEL SYSTEMS IN CRACKED AND UNCRACKED CONCRETE

1.0 REPORT PURPOSE AND SCOPE

Purpose:

The purpose of this evaluation report supplement is to indicate that the Jordahl Anchor Channel Systems in cracked and uncracked concrete, described in ICC-ES evaluation report [ESR-2854](#), have also been evaluated for compliance with the codes noted below, as adopted by the Los Angeles Department of Building and Safety (LADBS).

Applicable code editions:

- 2023 *City of Los Angeles Building Code* ([LABC](#))
- 2023 *City of Los Angeles Residential Code* ([LARC](#))

2.0 CONCLUSIONS

The Jordahl Anchor Channel Systems in cracked and uncracked concrete, described in Sections 2.0 through 7.0 of the evaluation report [ESR-2854](#), comply with the LABC Chapter 19, and the LARC, and are subject to the conditions of use described in this supplement.

3.0 CONDITIONS OF USE

The Jordahl Anchor Channel Systems in cracked and uncracked concrete described in this evaluation report supplement must comply with all of the following conditions:

- All applicable sections in the evaluation report [ESR-2854](#).
- The design, installation, conditions of use and identification of the Jordahl anchor channel systems are in accordance with the 2021 *International Building Code*® (IBC) provisions noted in the evaluation report [ESR-2854](#).
- The design, installation and inspection are in accordance with additional requirements of LABC Chapters 16 and 17, as applicable.
- Under the LARC, an engineered design in accordance with LARC Section R301.1.3 must be submitted.
- The allowable stress and strength design values listed in the evaluation report and tables are for the connection of the anchor channel systems to the concrete. The connection between the anchor channel systems and the connected members shall be checked for capacity (which may govern).

This supplement expires concurrently with the evaluation report, reissued April 2026.

DIVISION: 03 00 00—CONCRETE
Section: 03 15 19—Cast-In Concrete Anchors
Section: 03 16 00—Concrete Anchors

REPORT HOLDER:

JORDAHL

EVALUATION SUBJECT:

JORDAHL ANCHOR CHANNEL SYSTEMS IN CRACKED AND UNCRACKED CONCRETE

1.0 REPORT PURPOSE AND SCOPE**Purpose:**

The purpose of this evaluation report supplement is to indicate that the Jordahl Anchor Channel Systems in cracked and uncracked concrete, described in ICC-ES evaluation report [ESR-2854](#), have also been evaluated for compliance with the codes noted below.

Applicable code editions:

- 2023 Florida Building Code—Building
- 2023 Florida Building Code—Residential

2.0 CONCLUSIONS

The Jordahl Anchor Channel Systems in cracked and uncracked concrete, described in Sections 2.0 through 7.0 of the evaluation report [ESR-2854](#), comply with the *Florida Building Code—Building* and the *Florida Building Code—Residential*. The design requirements must be determined in accordance with the *Florida Building Code—Building* or the *Florida Building Code—Residential*, as applicable. The installation requirements noted in ICC-ES evaluation report [ESR-2854](#) for the 2021 *International Building Code*® meet the requirements of the *Florida Building Code—Building* or the *Florida Building Code—Residential*, as applicable.

Use of the Jordahl anchor channel systems has also been found to be in compliance with the High-Velocity Hurricane Zone provisions of the *Florida Building Code—Building* and the *Florida Building Code—Residential* with the following condition:

- a.) For anchorage to wood members, the connection subject to uplift must be designed for no less than 700 pounds (3114 N) in accordance with item 3 of Section 2321.7 of the *Florida Building Code—Building*.

For products falling under Florida Rule 61G20-3, verification that the report holder's quality assurance program is audited by a quality assurance entity approved by the Florida Building Commission for the type of inspections being conducted is the responsibility of an approved validation entity (or the code official when the report holder does not possess an approval by the Commission). Florida Rule 61G20-3 is applicable to products and/or systems which comprise the building envelope and structural frame for compliance with the structural requirements of the Florida Building Code.

This supplement expires concurrently with the evaluation report, reissued April 2026.